

# USER MANUAL



## Solar Hybrid Inverter

HESP4830SH3 | HESP4840SH3 | HESP4850SH3  
HESP4860SH3 | HESP4870SH3 | HESP4880SHD3

# CONTENTS

|   |           |
|---|-----------|
| <b>1.Safety</b> .....   | <b>1</b>  |
| 1.1 How to use this manual .....  | 1         |
| 1.2 Symbols in this manual .....  | 1         |
| 1.3 Safety instruction .....  | 1         |
| <b>2.Production instructions</b> .....  | <b>2</b>  |
| 2.1 Instructions .....  | 2         |
| 2.2 Features .....  | 2         |
| 2.3 System connection diagram .....   | 3         |
| 2.4 Production overview .....   | 4         |
| 2.5 Dimension drawing .....   | 5         |
| <b>3.Installation</b> .....   | <b>6</b>  |
| 3.1 Select the mount location .....   | 6         |
| 3.2 Packing lists .....   | 7         |
| 3.3 Mount the inverter .....  | 8         |
| 3.4 Removing the Terminal Protection Cover .....                                      | 9         |
| <b>4.Connection</b> .....   | <b>9</b>  |
| 4.1 Three-phase mode .....  | 9         |
| 4.2 Cable & circuit breaker selection .....   | 10        |
| 4.3 AC Input, output and generator wiring .....                                       | 11        |
| 4.4 Battery connection .....  | 12        |
| 4.5 PV connection .....   | 13        |
| 4.6 Dry contact connection .....  | 14        |
| 4.7 Grounding connection .....  | 14        |
| 4.8 Final assembly .....  | 14        |
| 4.9 Parallel connection wiring .....  | 15        |
| <b>5.Operation</b> .....  | <b>19</b> |
| 5.1 Operation and display panel .....   | 19        |
| 5.2 Setting .....   | 23        |
| 5.3 Charging/discharging function by days of the week and time of the day .....       | 35        |
| <b>6.Communication</b> .....  | <b>37</b> |
| 6.1 Overview .....  | 37        |
| 6.2 USB-1 port .....  | 38        |
| 6.3 WIFI port .....   | 38        |
| 6.4 RS485 port .....  | 39        |
| 6.5 CAN port .....  | 40        |
| 6.6 USB-2 port .....  | 40        |
| 6.7 DRMS(Only Australia) .....  | 40        |
| 6.8 External CT wiring (CT direction pointing toward the inverter) .....              | 41        |
| 6.9 Three-phase meter wiring (CT direction pointing towards the grid)(Optional) ..... | 42        |
| 6.10 AC coupling function wiring .....  | 43        |
| 6.11 AC coupling function .....   | 44        |
| <b>7.Fault and Remedy</b> .....   | <b>45</b> |
| 7.1 Fault code .....  | 45        |
| 7.2 Partial Troubleshooting .....   | 48        |
| <b>8.Protection and maintenance</b> .....   | <b>49</b> |
| 8.1 Protection function .....   | 49        |
| 8.2 Maintenance .....   | 50        |
| <b>9.Datasheet</b> .....  | <b>51</b> |

# 1.Safety

## 1.1 How to use this manual





This manual contains important information, guidelines, operation and maintenance for the following products :

HESP series HESP4830SH3 ~ HESP4870SH3、 HESP4880SHD3.

This manual must be followed during installation, use and maintenance.

## 1.2 Symbols in this manual

---

|  |  |
|--|--|
|  <b>DANGER</b>  | DANGER: Indicates a hazardous situation which, if not avoided, will result in death or serious injury.   |
|  <b>WARNING</b> | WARNING: Indicates a hazardous situation which, if not avoided, could result in death or serious injury. |
|  <b>CAUTION</b> | CAUTION: Indicates a hazardous situation which, if not avoided, may result in minor or moderate injury.  |
|  <b>NOTICE</b> | NOTICE: Provides tips or cues regarding product operation.   |

---

## 1.3 Safety instruction

This chapter contains important safety instructions. Read and keep this manual for future reference.

- Be sure to comply the local requirements and regulation to install this inverter.
- Beware of high voltage. Please turn off the switch of each power sources before and during the installation to avoid electric shock.
- For optimal operation of this inverter, select the appropriate cable size and the necessary protective devices as specified.
- Do not connect or disconnect any connections when the inverter working.
- Do not open the terminal cover when the inverter working.
- Make sure the inverter is well grounding.
- Be careful not to cause short-circuiting of the AC output and DC input.
- Do not disassembly this unit, for all repair and maintenance, please take it to the professional service center.
- Never charge a frozen battery.

## 2. Production instructions

### 2.1 Instructions

The HESP series, including HESP4830SH3 - HESP4870SH3 and the HESP4880SHD3 series, is a new type of solar energy storage inverter control inverter integrating solar energy storage & utility charging and energy storage, AC sine wave output. It adopts DSP control and features high response speed, reliability, and industrial standard through an advanced control algorithm.

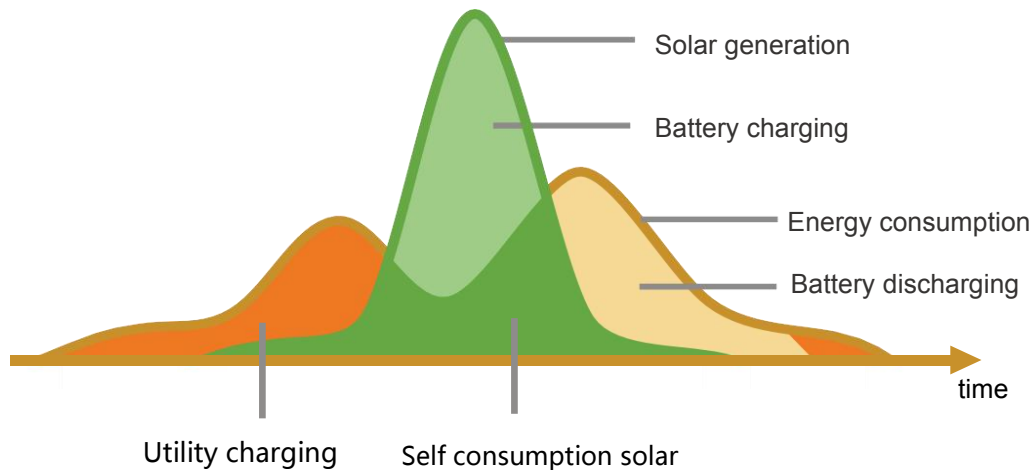

### 2.2 Features

- Supports lead-acid battery and li-ion battery connections.
- With a dual activation function when the li-ion battery is dormant; either mains or photovoltaic power supply access can trigger the activation of the li-ion battery.
- Support three-phase pure sine wave output (350~415V).
- Supports phase voltage adjustment in the range of 200Vac, 208Vac, 220Vac, 230Vac, 240Vac.
- Supports two PV inputs, with the function of simultaneously tracking the maximum power charging or carrying capacity of two MPPT.
- Dual MPPT, efficiency up to 99.9%, single maximum current of 26A, perfectly adapted to high-power modules.
- 2 charging modes are available: solar only, grid and PV hybrid charging.
- With time-slot charging and discharging setting function, it helps users to take advantage of peak and valley tariffs and save electricity costs.
- Energy-saving mode function to reduce no-load energy losses.
- With two output modes of utility bypass and inverter output, with uninterrupted power supply function.
- LCD large screen dynamic flow diagram design, easy to understand the system data and operation status.
- 360° protection with complete short-circuit protection, over-current protection, over-voltage protection, under-voltage protection, over-load protection, etc.
- Support CAN, USB, and RS485 communication.

## 2.3 System connection diagram

The diagram below shows the system application scenario of this product. A complete system consists of the following components:

- **Solar modules:** Converts light energy into DC energy, which can be used to charge the battery via an inverter or directly inverted into AC power to supply the load.
- **Grid or generator:** Connected to the AC input, either of the connected grid and generator can charge the battery while supplying the load. When the batteries and photovoltaic modules supply the load, the system can operate without the grid or generator.
- **Battery:** The role of the battery is to ensure the normal power supply of the system loads in case of insufficient photovoltaic and no grid power.
- **Home load:** connects to a variety of home and office loads including refrigerators, lamps, TVs, fans, air conditioners and other AC loads.
- **Inverter:** It is the energy conversion device of the whole system.

The actual application scenario determines the specific system cabling.

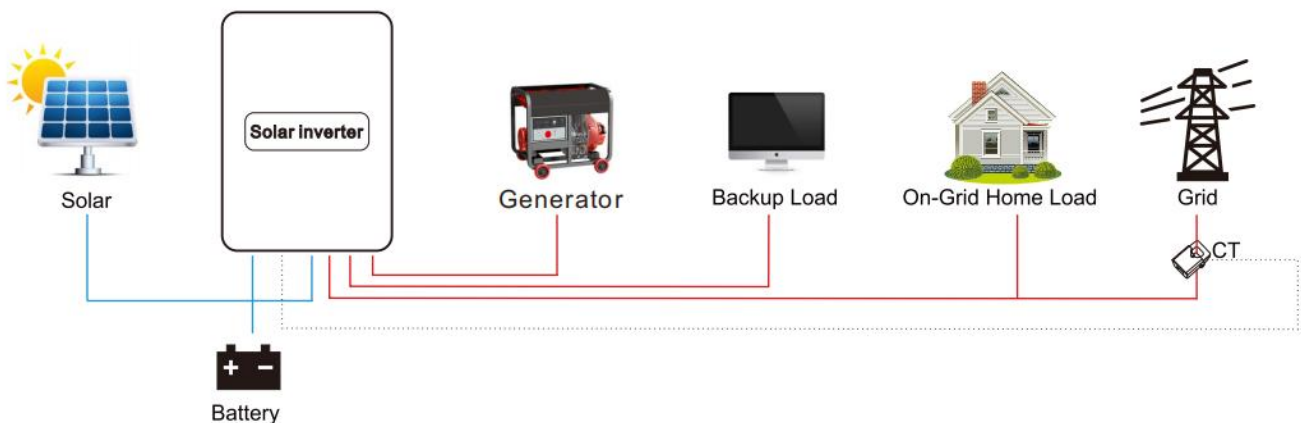

## 2.4 Production overview

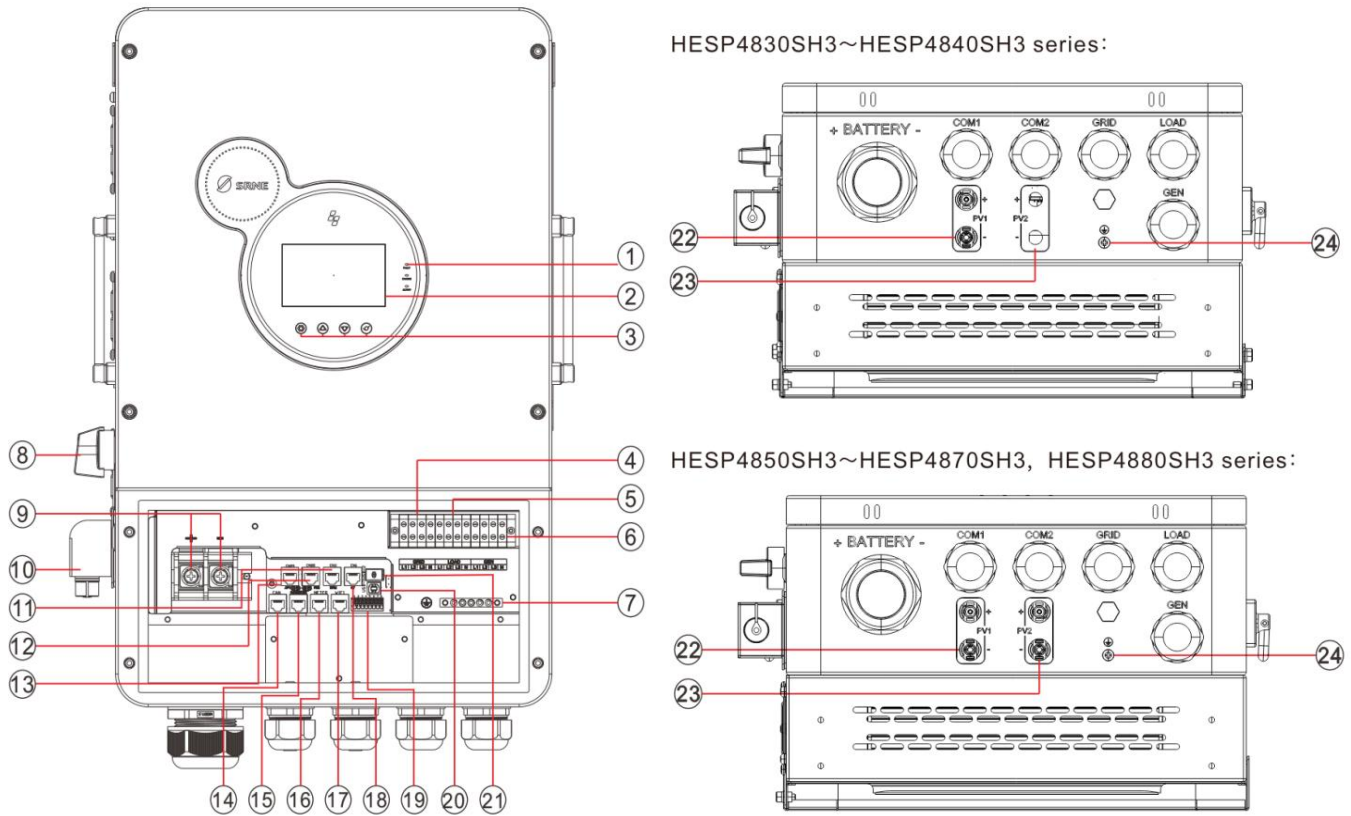

|    |                               |    |  |    |                               |
|----|-------------------------------|----|--|----|-------------------------------|
| 1  | LED indicator                 | 2  | LCD screen   | 3  | Physical buttons              |
| 4  | Grid port                     | 5  | Load port  | 6  | Generator port                |
| 7  | Ground bus                    | 8  | PV circuit breaker   | 9  | Battery terminal              |
| 10 | WIFI 2 ports                  | 11 | DRMS port  | 12 | Parallel communication port B |
| 13 | Parallel communication port A | 14 | CAN communication port   | 15 | 485 communication port        |
| 16 | Meter port                    | 17 | WIFI 1 port  | 18 | CT port                       |
| 19 | Dry contact                   | 20 | USB-1 port   | 21 | USB-2 port                    |
| 22 | PV1 port                      | 23 | PV2 port<br>(For HESP4850SH3 to HESP4870SH3 and HESP4880SHD3 series only.) | 24 | Ground terminal               |

## 2.5 Dimension drawing

HESP4830SH3~HESP4840SH3 series:

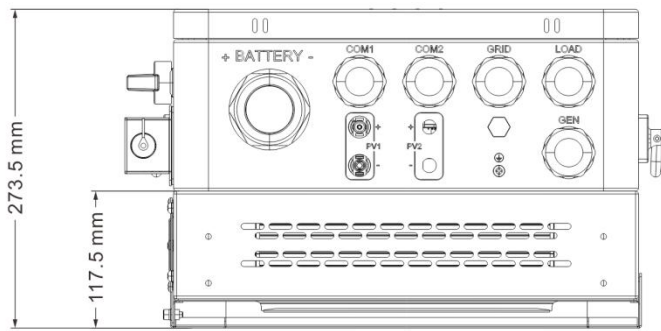

HESP4850SH3~HESP4870SH3, HESP4880SH3 series:

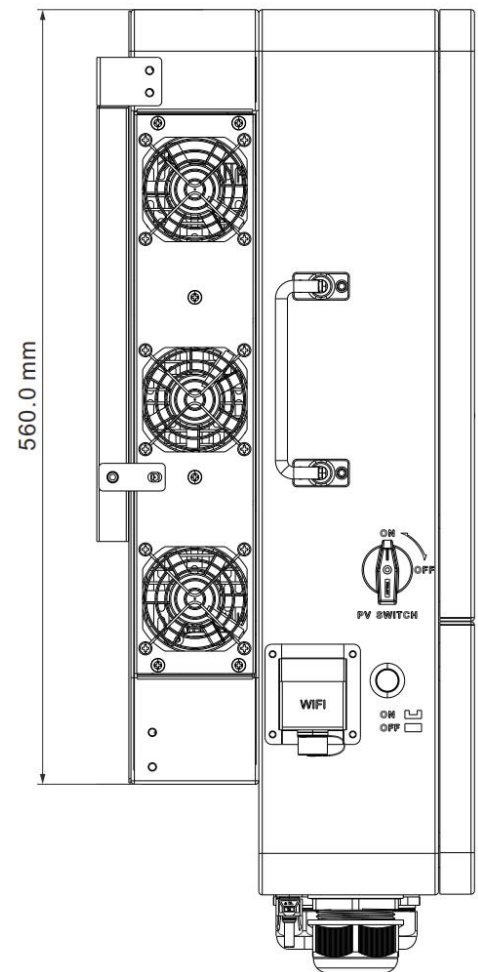
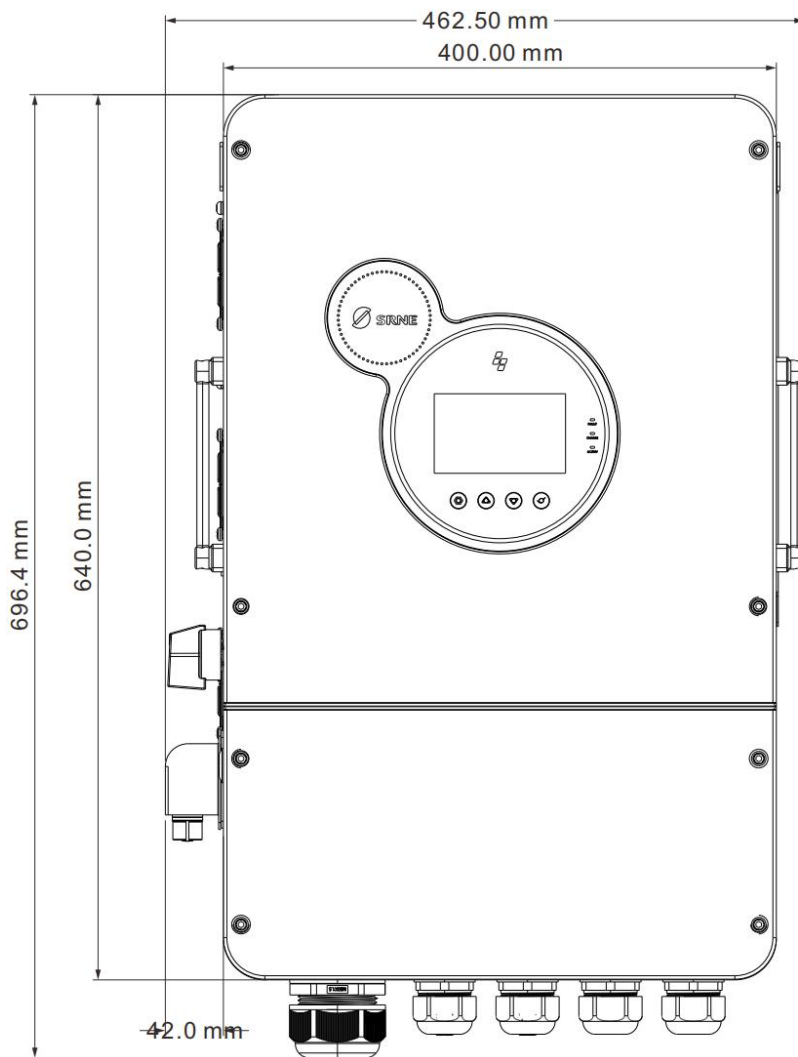
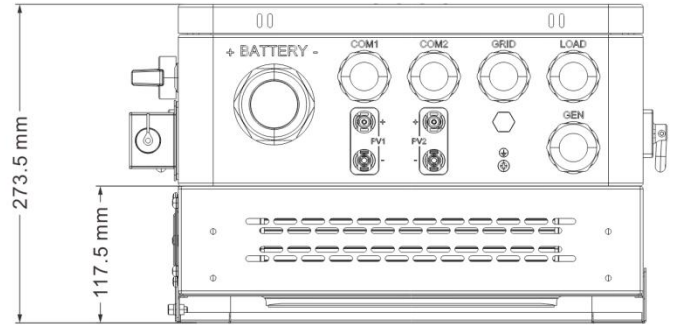

# 3.Installation

## 3.1 Select the mount location

The HESP series, including HESP4830SH3 to HESP4870SH3 and HESP4880SHD3, can be used outdoors (with an protection rating of IP65). Before choosing the installation location, users are requested to consider the following factors.

- Choose the solid wall to install the inverter.
- Mount the inverter at eye level.
- Adequate heat dissipation space must be provided for the inverter.
- The ambient temperature should be between -25~60°C ( -13~140°F ) to ensure optimal operation.

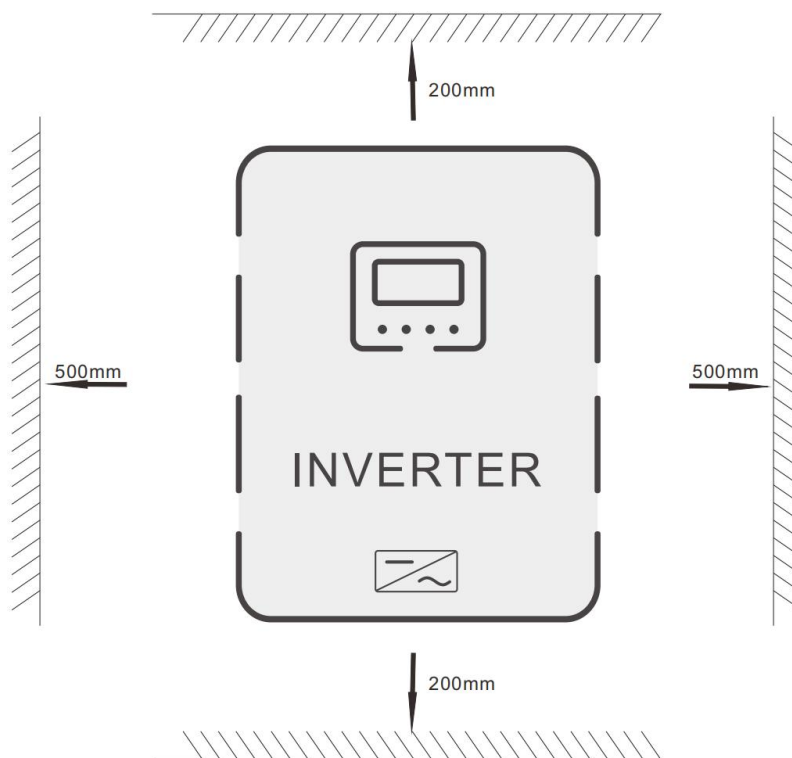







### DANGER

- Do not install the inverter near highly flammable materials.
- Do not install the inverter in a potentially explosive area.
- Do not install the inverter in a confined space with lead-acid batteries.

### CAUTION

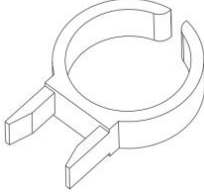
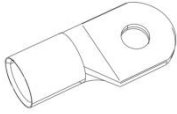
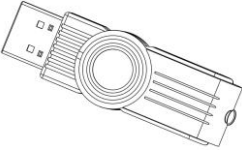
- Do not install the inverter in direct sunlight.
- Do not install or use the inverter in a humid environment.

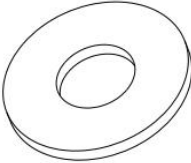
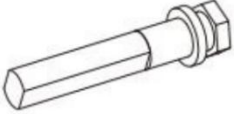
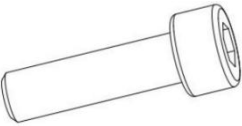
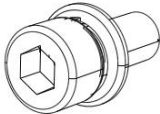
## 3.2 Packing lists

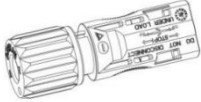
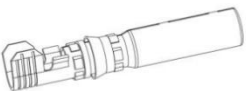
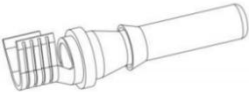
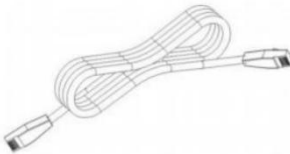
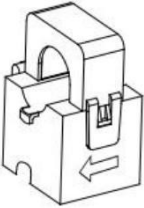
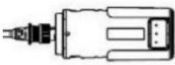
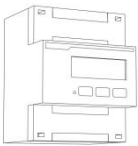
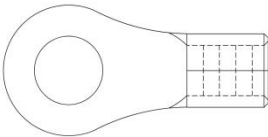
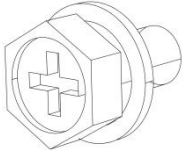
|   |   |  |  |
|---|---|--|--|
|  <p>Inverter<br/>x 1pcs</p>                  |  <p>Wall bracket<br/>x 1pcs</p>  |  <p>MC4 unlocking tool<br/>x 1pcs</p>    |  <p>Cold pressed terminals<br/>SC70-10<br/>x 2pcs</p>           |
|  <p>USB Flash Drive<br/>x 1pcs</p>           |  <p>Hex key 4 mm<br/>x 1pcs</p>  |  <p>M8 Flat Washer<br/>x 4pcs</p>        |  <p>Expansion bolt<br/>M8*60mm<br/>x 4pcs</p>                   |
|  <p>Spare Screws<br/>M5*18mm<br/>x 1pcs</p> |  <p>Socket head cap three<br/>- in - one screw<br/>M5*12mm<br/>x 2pcs</p> |  <p>PV+ Terminal<br/>x 2pcs</p>        |  <p>PV- Terminal<br/>x 2pcs</p>                               |
|  <p>PV+ input Metal Core<br/>x 2pcs</p>    |  <p>PV- input Metal<br/>Core</p>   |  <p>Parallel Connection<br/>Wire</p>   |  <p>Current Transformer<br/>x 3pcs</p>                        |
|  <p>WIFI Module<br/>x 1pcs</p>             |  <p>Three - phase Electric<br/>Meter (optional)<br/>x 1pcs</p>           |  <p>Round Bare Terminal<br/>x 3pcs</p> |  <p>Hexagon Socket with<br/>Cross Recess Screw<br/>x 3pcs</p> |

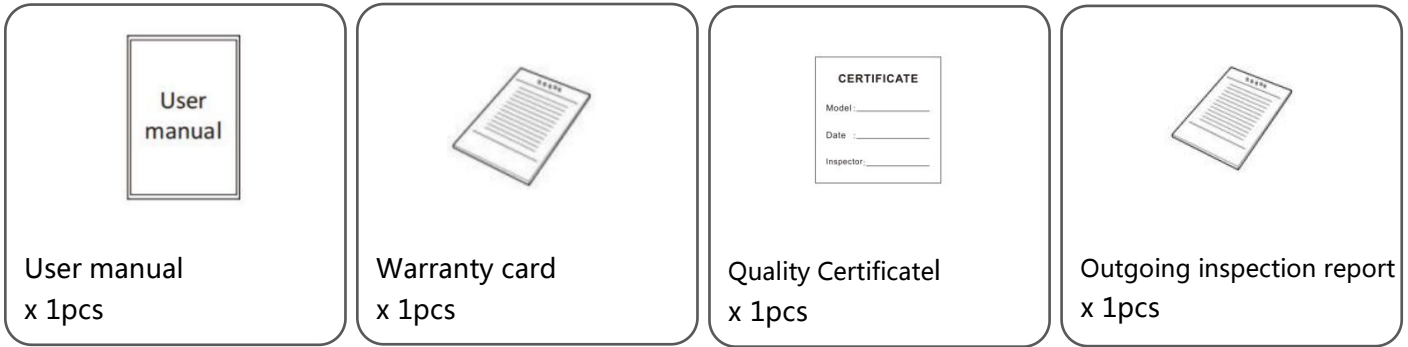

### 3.3 Mount the inverter

**Step 1:** Select the wall with sufficient bearing capacity, the wall bracket will be horizontally affixed to the wall with the installation of the wall, with a marker pen on the wall to mark the fixed wall bracket needs to be drilled position, and then use the impact drill to drill holes in the wall, drilling to keep the impact drill perpendicular to the wall, do not shake, so as not to damage the wall, if the hole drilling error is large need to reposition.

**Step 2:** Vertically insert the M8×60 expansion bolts into the holes. Pay attention to the insertion depth of the expansion bolts (it should not be too shallow).

**Step 3:** Align the wall - mounted bracket with the hole positions and fix the wall - mounted bracket to the wall with nuts.

**Step 4:** First, hang the inverter on the wall - mounted bracket, and then fix the inverter to the wall - mounted bracket with M6 socket - head cap screws.

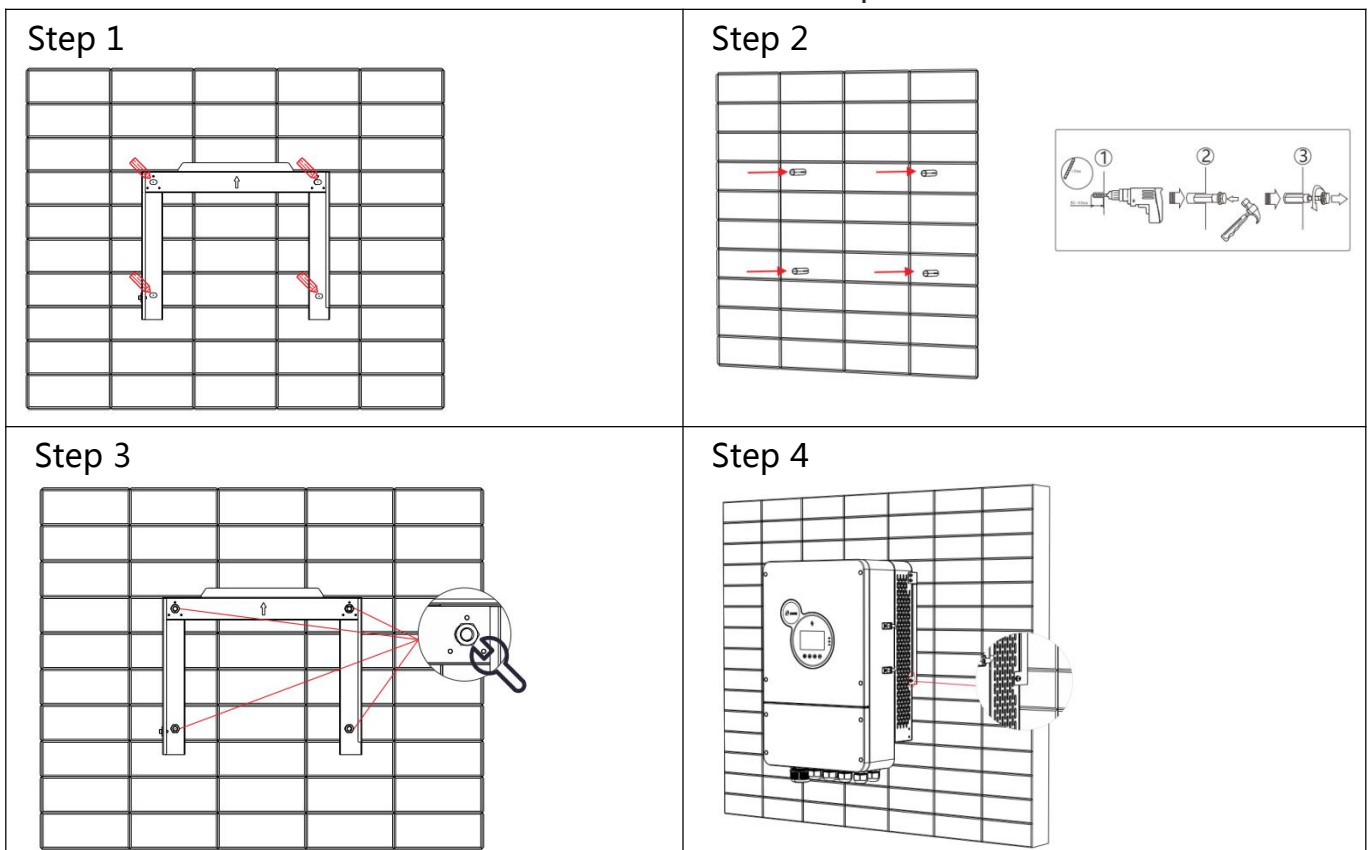

## 3.4 Removing the Terminal Protection Cover

Use a hexagon screwdriver to remove the terminal protection cover.

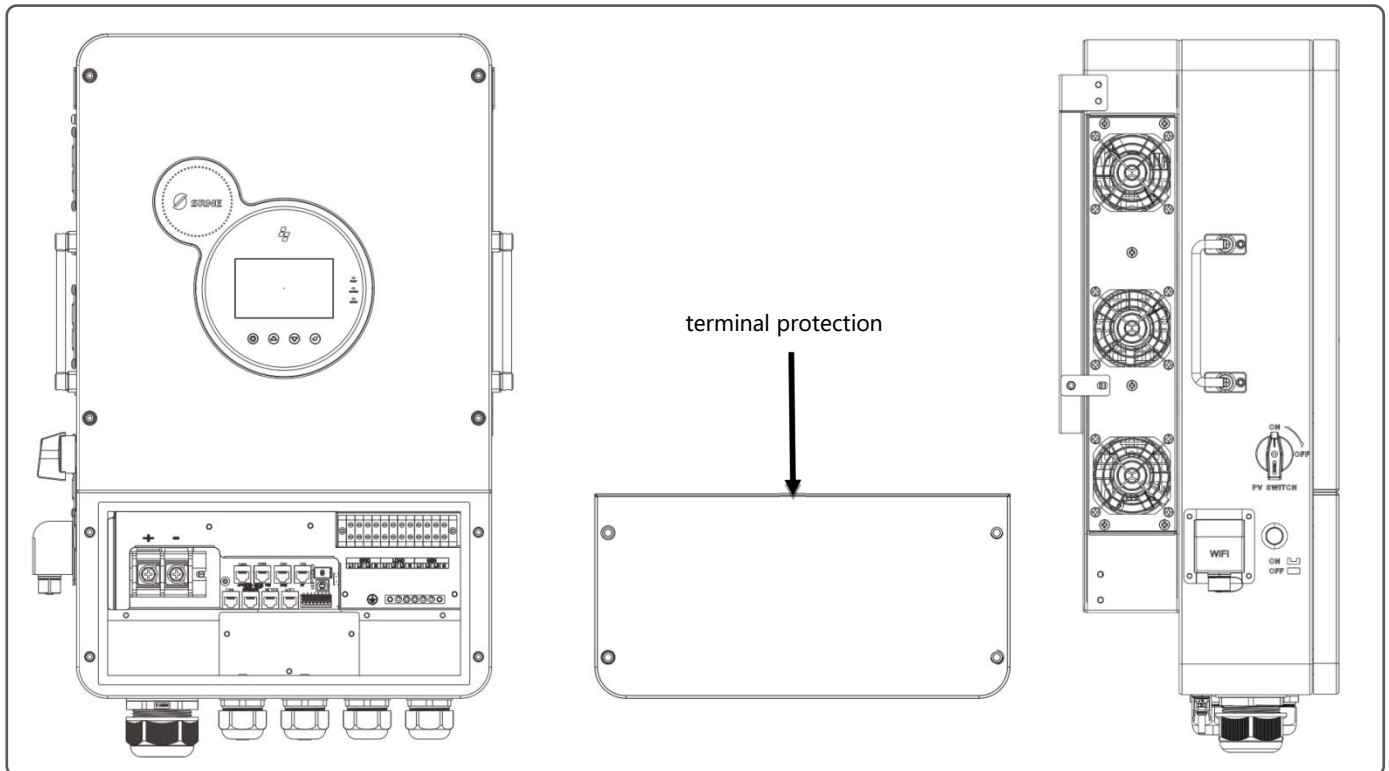

### NOTICE

When using the device in areas with poor air quality, the dust screen is easily blocked by air particles. Please disassemble and clean the dust screen periodically to avoid affecting the internal air flow rate of the inverter, which may trigger an over-temperature protection fault (19/20 fault) affecting the use of the power supply and the service life of the inverter.

## 4.Connection

### 4.1 Three-phase mode

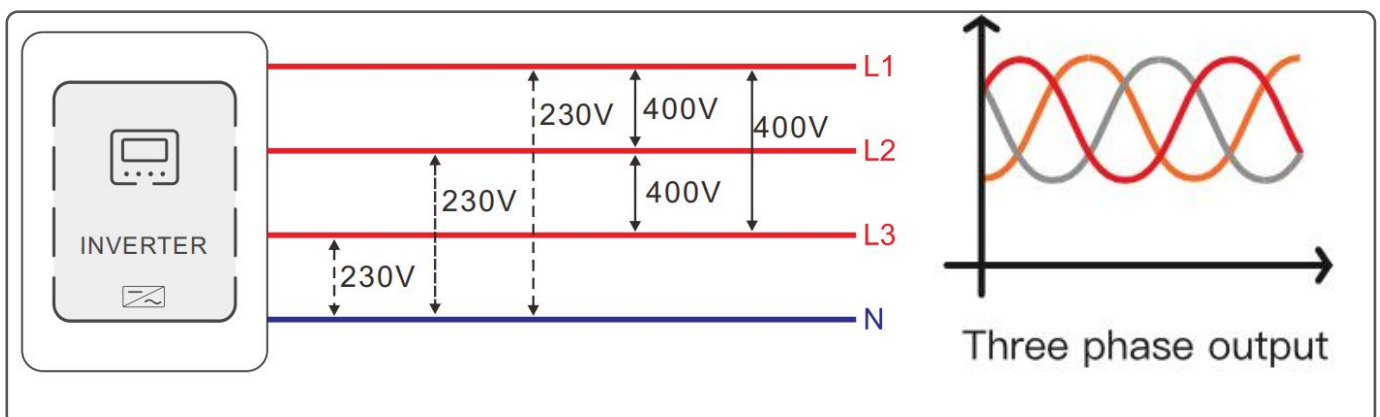

| Items                         | Description  |
|-------------------------------|--|
| Applicable models             | The HESP series, including HESP4830SH3 to HESP4870SH3 and HESP4880SHD3 |
| AC output phase voltage (L-N) | 200~240Vac, 230Vac default   |

 **NOTICE**

- Users can change the output phase mode and output voltage through the setting menu. For details, please refer to Chapter 5.2.
- The output voltage corresponds to the parameter setting of [output phase voltage]. The output phase voltage can be set within the range of 200V ~ 240V.

## 4.2 Cable & circuit breaker selection

### ■ PV input

| Models       | Recommended Wire Diameter | Max. Input Current |
|--------------|---------------------------|--------------------|
| HESP4830SH3  | 4mm <sup>2</sup> /12 AWG  | 26A                |
| HESP4840SH3  | 4mm <sup>2</sup> /12 AWG  | 26A                |
| HESP4850SH3  | 4mm <sup>2</sup> /12 AWG  | 26A                |
| HESP4860SH3  | 4mm <sup>2</sup> /12 AWG  | 26A                |
| HESP4870SH3  | 4mm <sup>2</sup> /12 AWG  | 26A                |
| HESP4880SHD3 | 4mm <sup>2</sup> /12 AWG  | 26A                |

### ■ AC input

| Models       | Mode          | Recommended Wire Diameter           | Max. Input Current |
|--------------|---------------|-------------------------------------|--------------------|
| HESP4830SH3  | Three - phase | 10mm <sup>2</sup> /8AWG(L1/L2/L3/N) | 45A                |
| HESP4840SH3  | Three - phase | 10mm <sup>2</sup> /8AWG(L1/L2/L3/N) | 45A                |
| HESP4850SH3  | Three - phase | 10mm <sup>2</sup> /8AWG(L1/L2/L3/N) | 45A                |
| HESP4860SH3  | Three - phase | 10mm <sup>2</sup> /8AWG(L1/L2/L3/N) | 45A                |
| HESP4870SH3  | Three - phase | 10mm <sup>2</sup> /8AWG(L1/L2/L3/N) | 45A                |
| HESP4880SHD3 | Three - phase | 10mm <sup>2</sup> /8AWG(L1/L2/L3/N) | 45A                |

### ■ Generator input

| Models       | Mode          | Recommended Wire Diameter           | Max. Input Current |
|--------------|---------------|-------------------------------------|--------------------|
| HESP4830SH3  | Three - phase | 10mm <sup>2</sup> /8AWG(L1/L2/L3/N) | 45A                |
| HESP4840SH3  | Three - phase | 10mm <sup>2</sup> /8AWG(L1/L2/L3/N) | 45A                |
| HESP4850SH3  | Three - phase | 10mm <sup>2</sup> /8AWG(L1/L2/L3/N) | 45A                |
| HESP4860SH3  | Three - phase | 10mm <sup>2</sup> /8AWG(L1/L2/L3/N) | 45A                |
| HESP4870SH3  | Three - phase | 10mm <sup>2</sup> /8AWG(L1/L2/L3/N) | 45A                |
| HESP4880SHD3 | Three - phase | 10mm <sup>2</sup> /8AWG(L1/L2/L3/N) | 45A                |

## ■ Battery

| Models       | Recommended Wire Diameter         | Max. Discharge Current |
|--------------|-----------------------------------|------------------------|
| HESP4830SH3  | 25mm <sup>2</sup> / 4 AWG ( M8 )  | 80A                    |
| HESP4840SH3  | 25mm <sup>2</sup> / 4 AWG ( M8 )  | 100A                   |
| HESP4850SH3  | 50mm <sup>2</sup> / 0 AWG ( M8 )  | 120A                   |
| HESP4860SH3  | 50mm <sup>2</sup> / 0 AWG ( M8 )  | 150A                   |
| HESP4870SH3  | 70mm <sup>2</sup> / 00 AWG ( M8 ) | 180A                   |
| HESP4880SHD3 | 70mm <sup>2</sup> / 00 AWG ( M8 ) | 200A                   |

## ■ AC Output

| Models       | Mode          | Max. Phase Current | Bypass Current | Recommended Wire Diameter           |
|--------------|---------------|--------------------|----------------|-------------------------------------|
| HESP4830SH3  | Three - phase | 6.9A               | 45A            | 10mm <sup>2</sup> /8AWG(L1/L2/L3/N) |
| HESP4840SH3  | Three - phase | 9.1A               | 45A            | 10mm <sup>2</sup> /8AWG(L1/L2/L3/N) |
| HESP4850SH3  | Three - phase | 11.4A              | 45A            | 10mm <sup>2</sup> /8AWG(L1/L2/L3/N) |
| HESP4860SH3  | Three - phase | 13.6A              | 45A            | 10mm <sup>2</sup> /8AWG(L1/L2/L3/N) |
| HESP4870SH3  | Three - phase | 15.9A              | 45A            | 10mm <sup>2</sup> /8AWG(L1/L2/L3/N) |
| HESP4880SHD3 | Three - phase | 18.2A              | 45A            | 10mm <sup>2</sup> /8AWG(L1/L2/L3/N) |

## 4.3 AC Input, output and generator wiring

Connect the live wire, neutral wire, and ground wire according to the cable positions and sequence shown in the figure below.

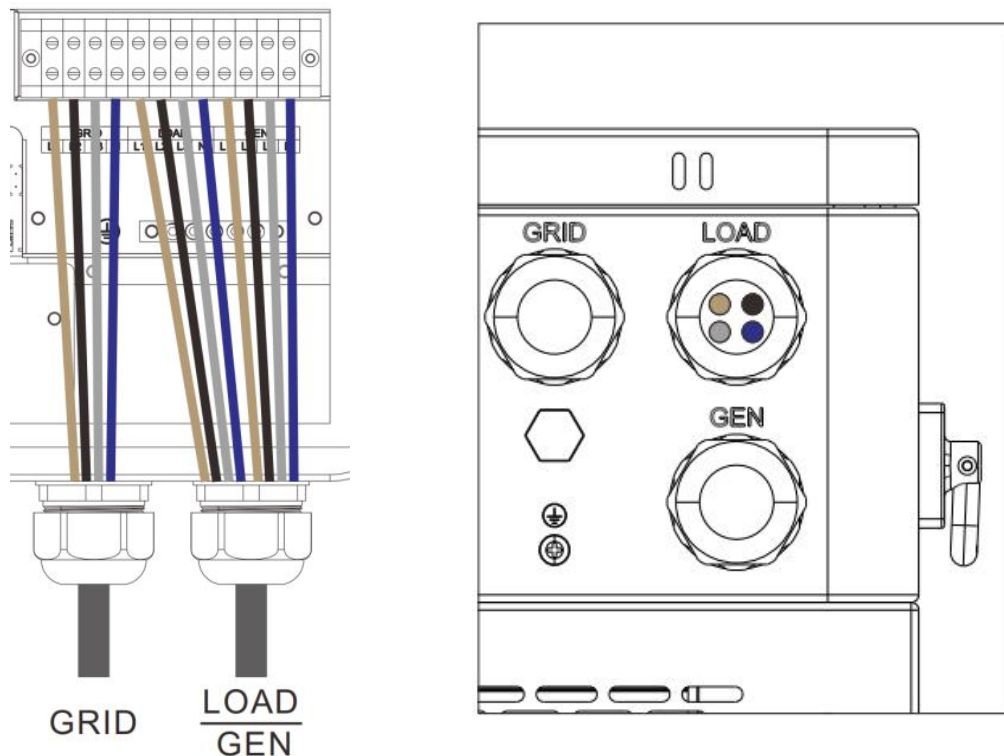

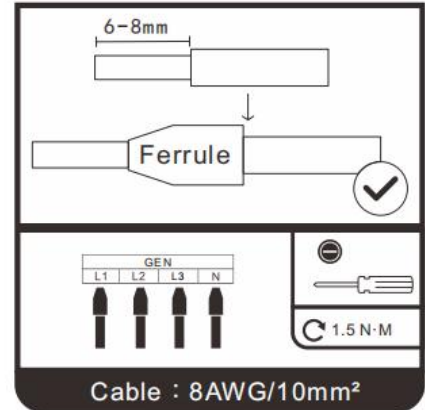
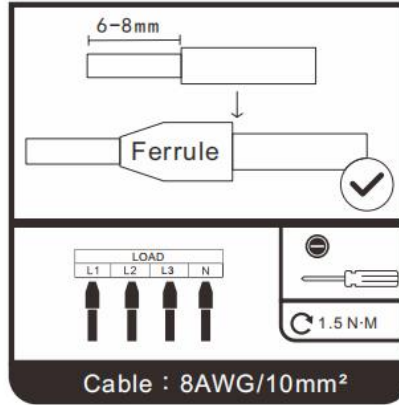
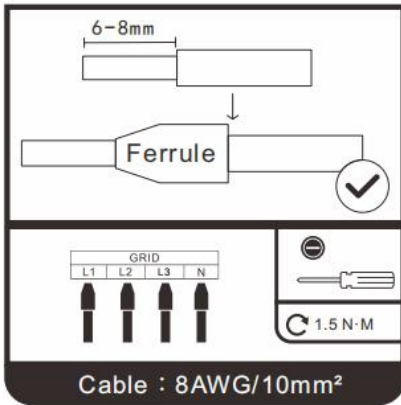

**⚠ DANGER**

- Before connecting the AC input and output, the circuit breaker must be disconnected to avoid the risk of electric shock and must not be operated with electricity.
- Please check that the cable used is sufficient for the requirements, too thin, poor quality cables are a serious safety hazard.

## 4.4 Battery connection

Connect the positive and negative cables of the battery according to the cable positions and sequence shown in the figure below.

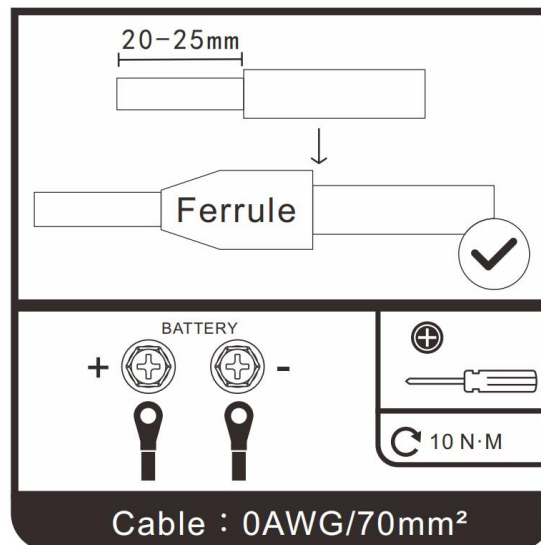
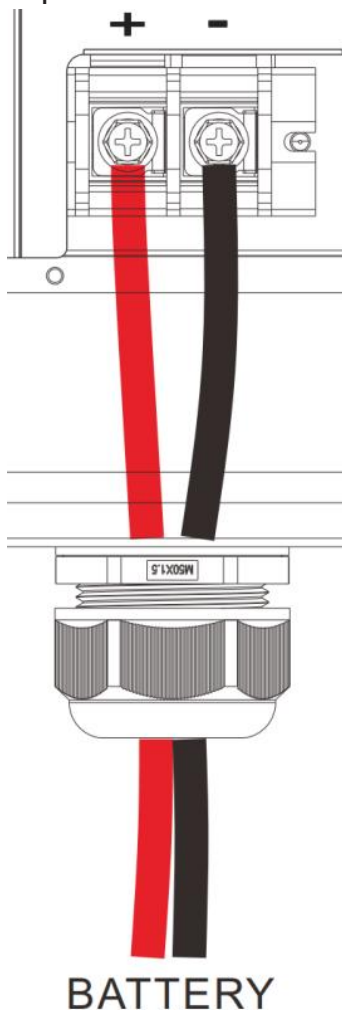

**⚠ DANGER**

- Before connecting the battery, the circuit breaker must be disconnected to avoid the risk of electric shock and must not be operated with electricity.
- Please ensure that the positive and negative terminals of the batteries are correctly connected and not reversed, otherwise the inverter may be damaged.
- Please check that the cable used is sufficient for the requirements, too thin, poor quality cables are a serious safety hazard.

## 4.5 PV connection

Connect the positive and negative wires of the two groups of photovoltaic (PV) systems according to the following chart, and connect the positive and negative wires of the two PV circuits in the specified cable positions and sequence.

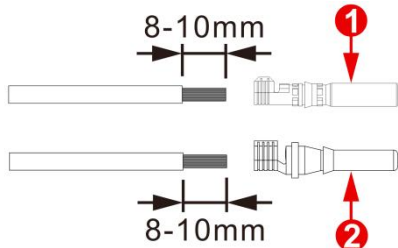
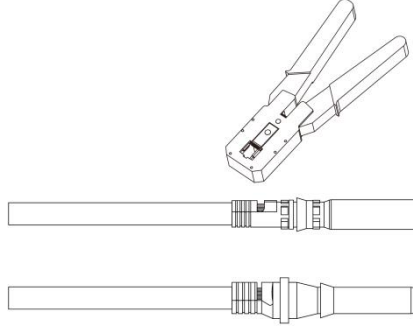
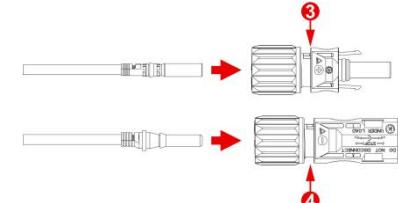
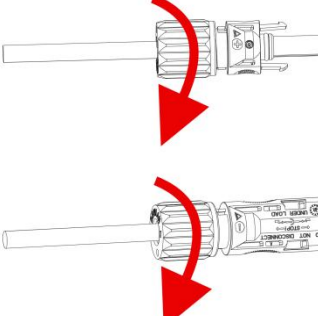
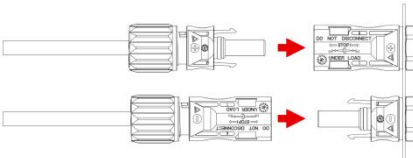
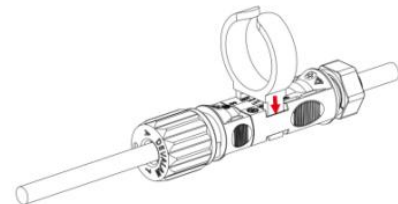
|  |  |   |
|--|--|---|
|  <p>① Positive pole metal<br/>② Negative pole metal</p> |  <p>Crimp terminals with a crimping tool.</p> |  <p>③ Positive terminal<br/>④ Negative terminal<br/>Insert until a "click" sound is heard.</p> |
|  <p>Tighten the terminals.</p>                         |  <p>Connect to the inverter.</p>             |  <p>Disconnect the PV terminals</p>   |

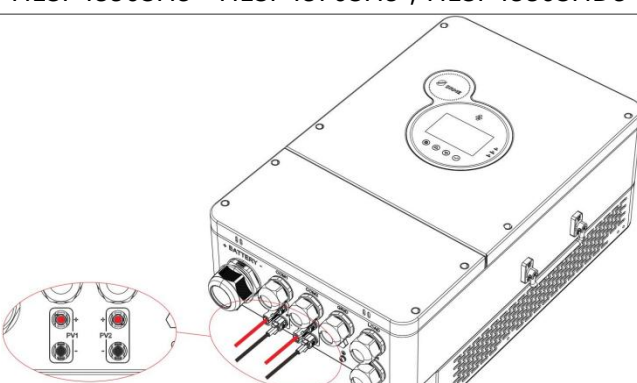
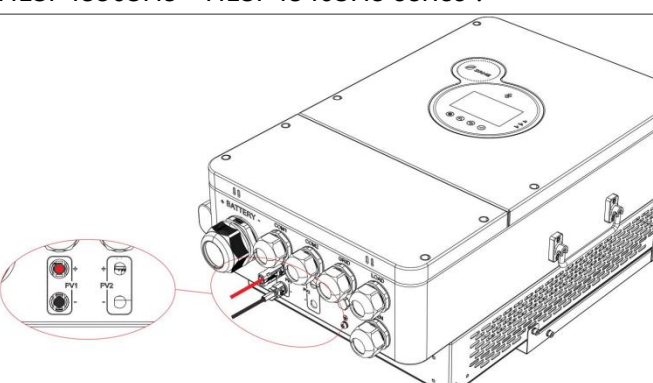
|   |  |
|---|--|
| <p>HESP4850SH3 ~ HESP4870SH3 , HESP4880SHD3</p>  | <p>HESP4830SH3 ~ HESP4840SH3 series :</p>  |
|---|--|

**⚠ DANGER**

- Before connecting the PV, the circuit breaker must be disconnected to avoid the risk of electric shock and must not be operated with electricity.
- Make sure that the open-circuit voltage of the PV modules connected in series does not exceed the maximum open-circuit voltage of the inverter (the value is 800V), otherwise the inverter may be damaged.

## 4.6 Dry contact connection

Use a small screwdriver to push back the direction indicated by the arrow, and then insert the communication cable into the dry junction port. (Communication cable cross section  $0.2\sim 1.5\text{mm}^2$ ).

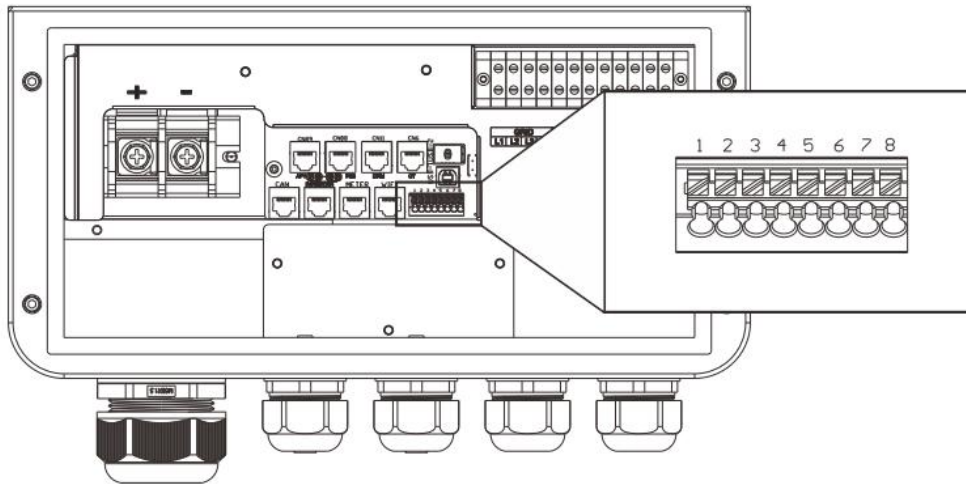

## 4.7 Grounding connection

Make sure that the earth terminal is securely connected to the grounding busbar.

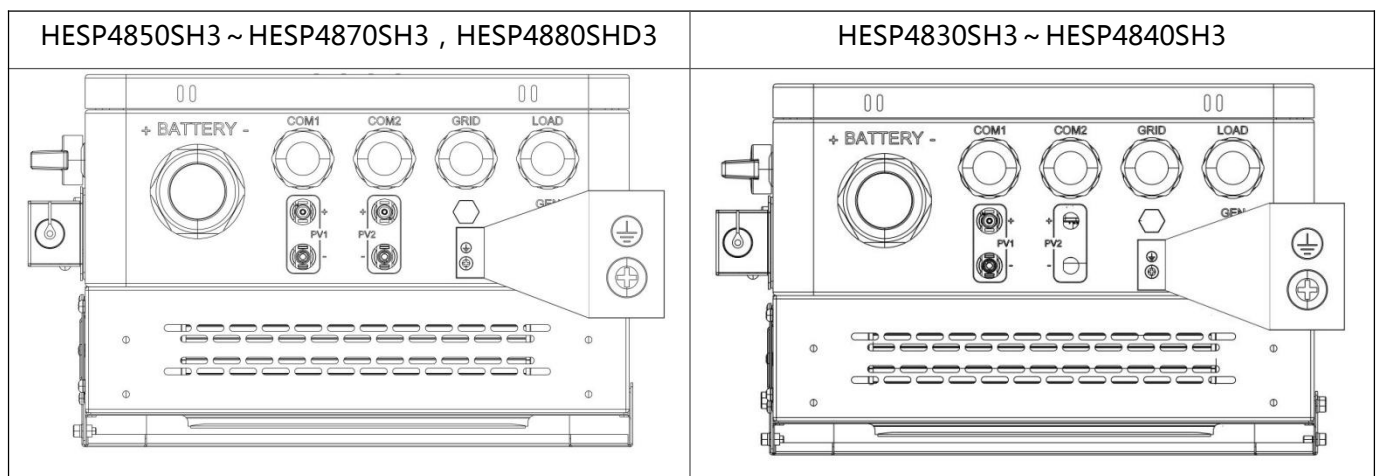

**NOTICE**

Grounding wire shall be not less than  $4\text{ mm}^2$  in diameter and as close as possible to the earthing point.

## 4.8 Final assembly

After ensuring reliable wiring and correct wire sequence, reinstall the terminal protection cover to its original position.

**Step 1:** Close the battery circuit breaker.

**Step 2:** Press the ON/OFF switch at the bottom of the inverter. Once the screen and indicator lights turn on, it indicates that the inverter has been activated.

**Step 3:** Close the circuit breakers of the photovoltaic, AC input, and AC output in sequence.

**Step 4:** Start the devices one by one in ascending order of power.

## 4.9 Parallel connection wiring

### 4.9.1 Introduction to parallel connection

- ① A maximum of six inverter-control integrated machines can be connected in parallel.
- ② When using the parallel connection function, it is necessary to correctly, stably and reliably connect the parallel communication cables. The following is the wiring diagram (packaging accessories):

**Parallel communication cable\*1**

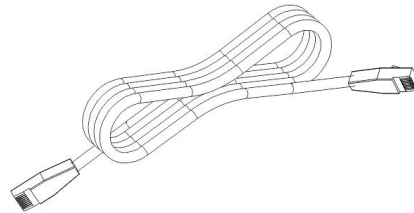

### 4.9.2 Cautions for parallel connection

 **Warning:**

#### 1.PV wiring:

In parallel connection, the PV array of each inverter must be independent, and the PV array of PV1 and PV2 for one inverter must also be independent.

#### 2.Battery wiring:

When connecting multiple parallel machines, all the inverse control integrated machines must be connected to the same battery, BAT+ connected to BAT+, BAT- connected to BAT-, and ensure that the connection is correct and the wiring length and wire diameter are the same before powering up and starting, to avoid the wrong connection caused by the output of the parallel system does not work properly.

#### 3.LOAD wiring:

When connecting multiple parallel machines, all inverse control integrated machines must be connected N to N wire and PE to PE. The L lines of all machines in the same phase need to be connected together, but the L lines of AC outputs of different phases cannot be connected together, refer to the wiring diagram.

L wires of all machines of the same phase need to be connected together, but L wires of AC outputs of different phases cannot be connected together, refer to the wiring diagram.

#### 4.GRID wiring:

When connecting multiple parallel machines, all inverse control integrated machines must be connected N to N wire and PE to PE. The L lines of all machines in the same

phase need to be connected together, but the AC input L lines between different phases cannot be connected together. Refer to the wiring diagram.

### 5. Communication wiring:

Our parallel communication cable is a 10 Pin network cable with shielding function, used for parallel connection, each machine needs to be connected with one out and one in, i.e., this machine "Parallel\_A" is connected to "Parallel\_B" of the machine that needs to be parallelized, and it is not possible to connect "Parallel\_A" to this machine "Parallel\_B" or this machine "Parallel\_A" to the machine that needs to be parallelized. The "Parallel\_A" connects to the "Parallel\_B" of this machine or the "Parallel\_A" connects to the "Parallel\_A" of the machine to be parallelized. ". At the same time, the parallel communication cable of each machine should be ensured that the 10 Pin network connection cable is fastened tightly, so as to prevent the parallel communication cable from falling off or having poor contact, which may cause the system output to work abnormally or be damaged.

6. Before connecting the system and after connecting the system, please refer to the following system wiring diagram in detail to ensure that all wiring is correct and reliable before powering up.

7. After the system is wired correctly and powered up for normal operation, if you need to add a new machine, you need to disconnect the battery input, PV input, AC input and AC output, and make sure that all the inverters are powered down before you rewire and connect to the system.

## 4.9.3 Schematic diagram of parallel connection

In the parallel connection mode, each inverter needs to be set to "Parallel".

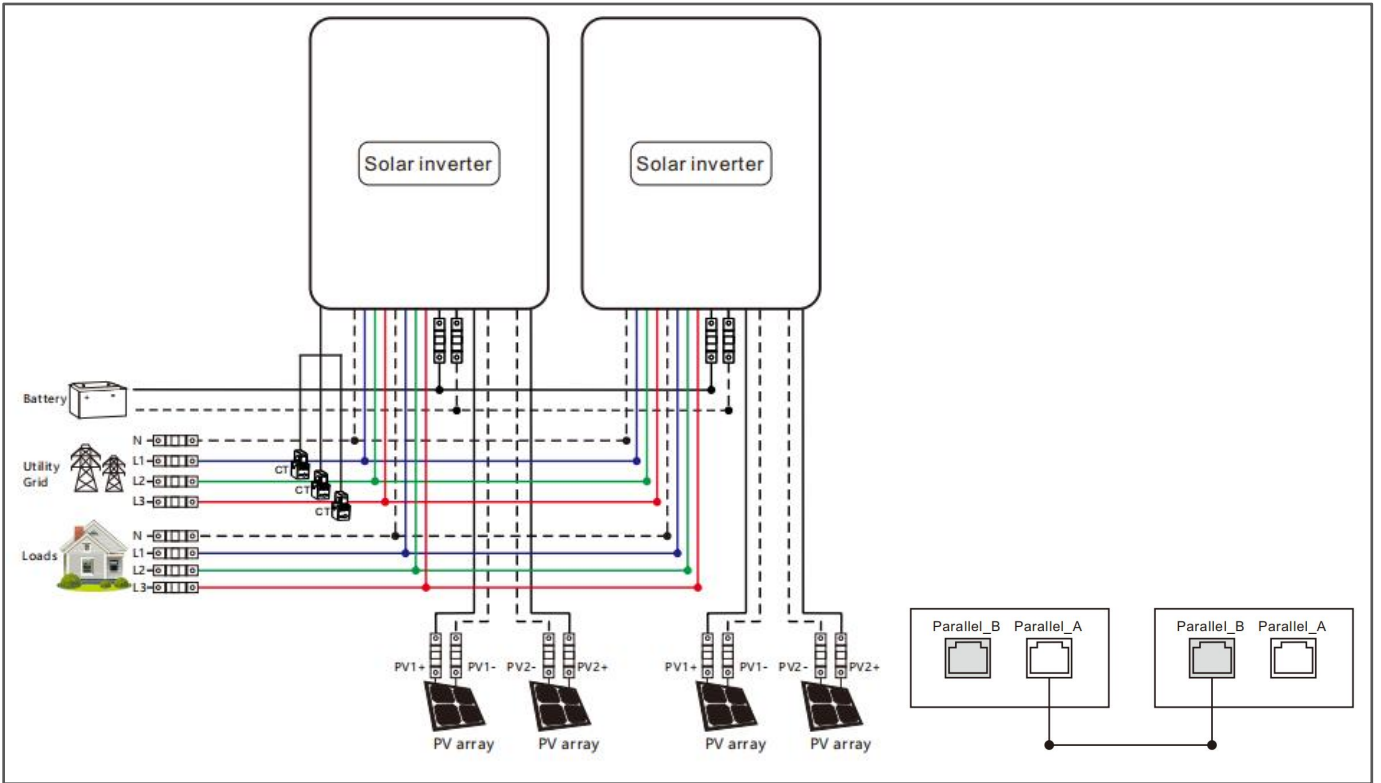
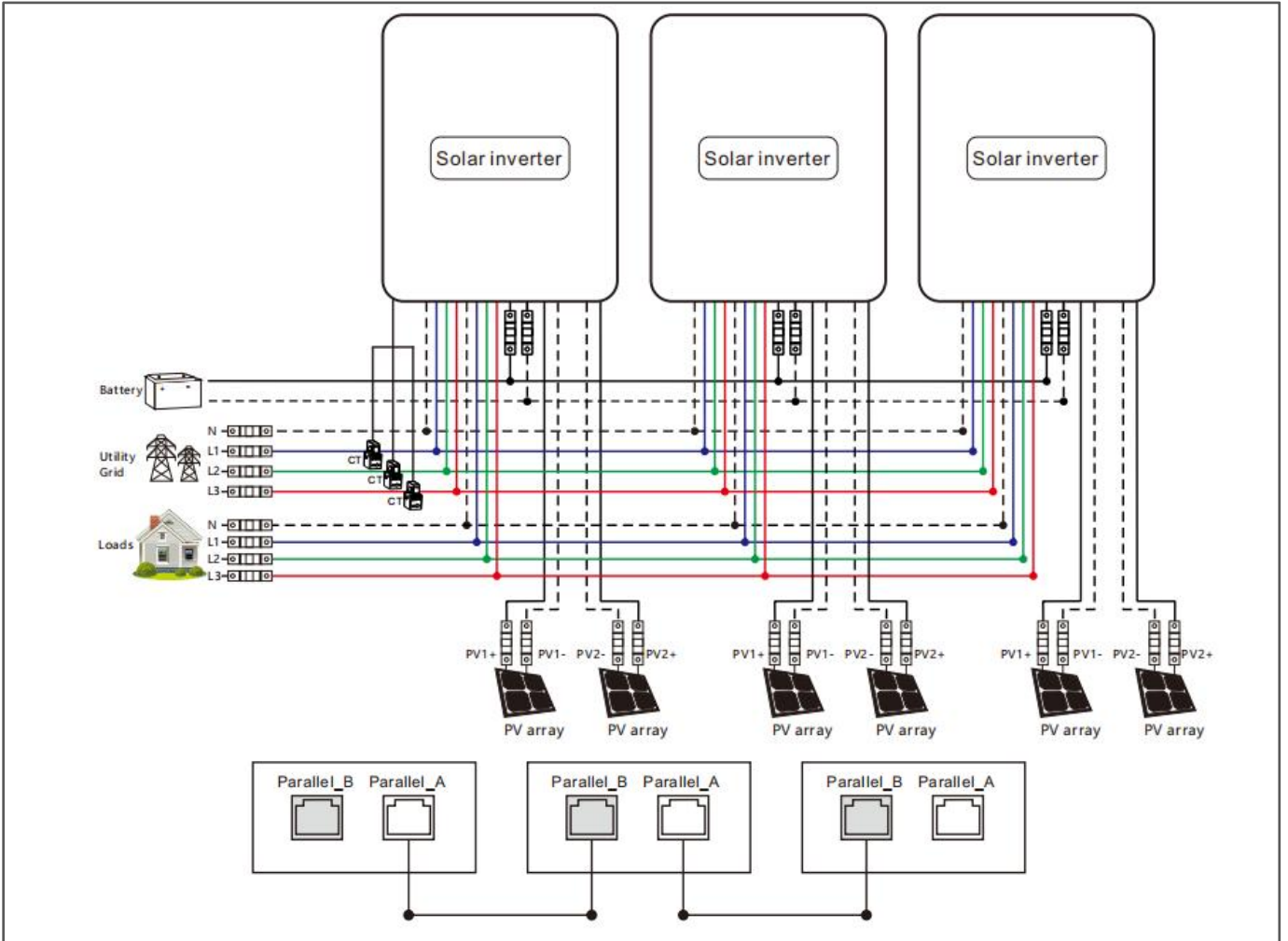

**A. Two units connected in parallel:**

**B. Three units connected in parallel:**

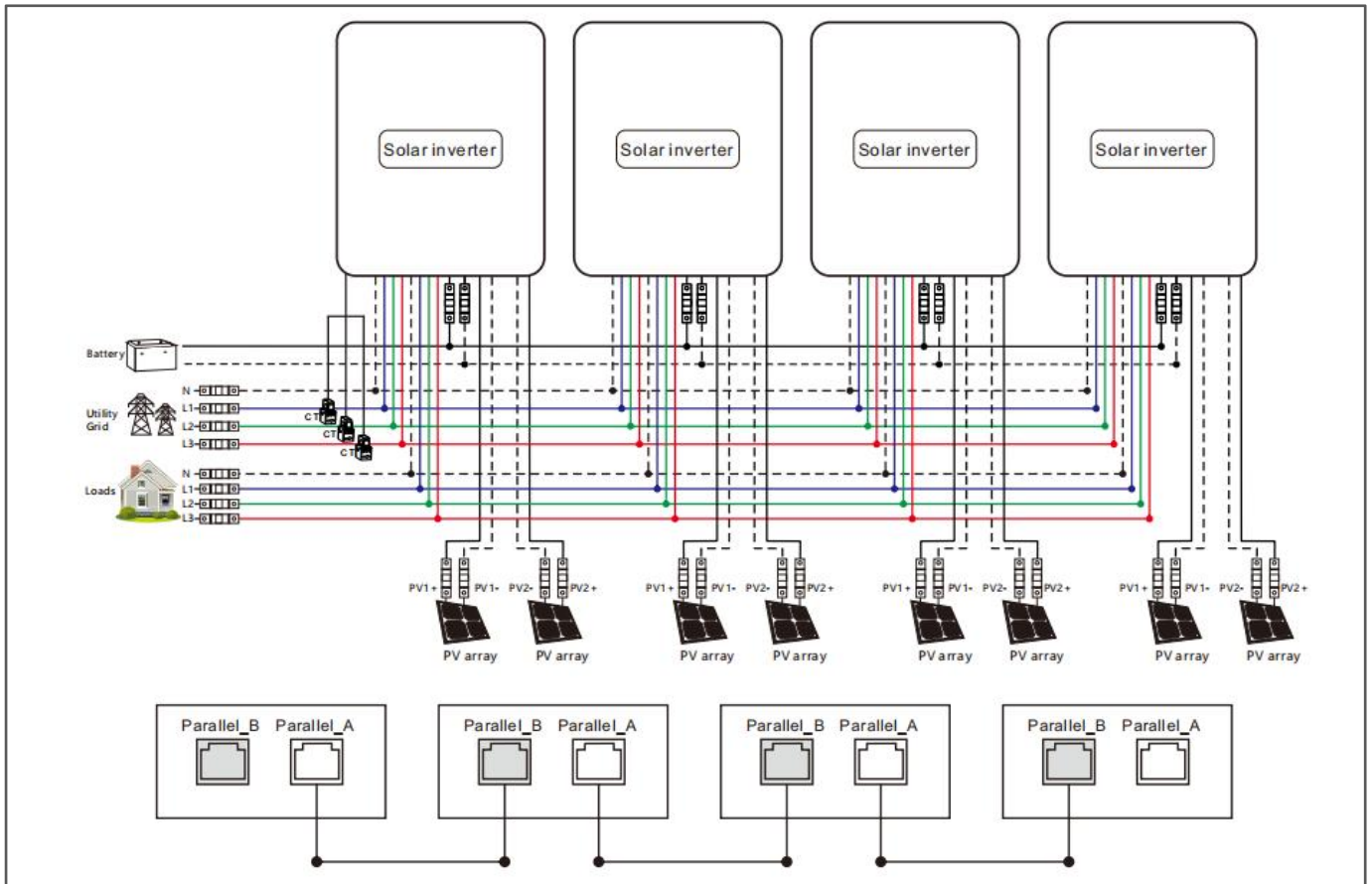
### C. Four units connected in parallel:

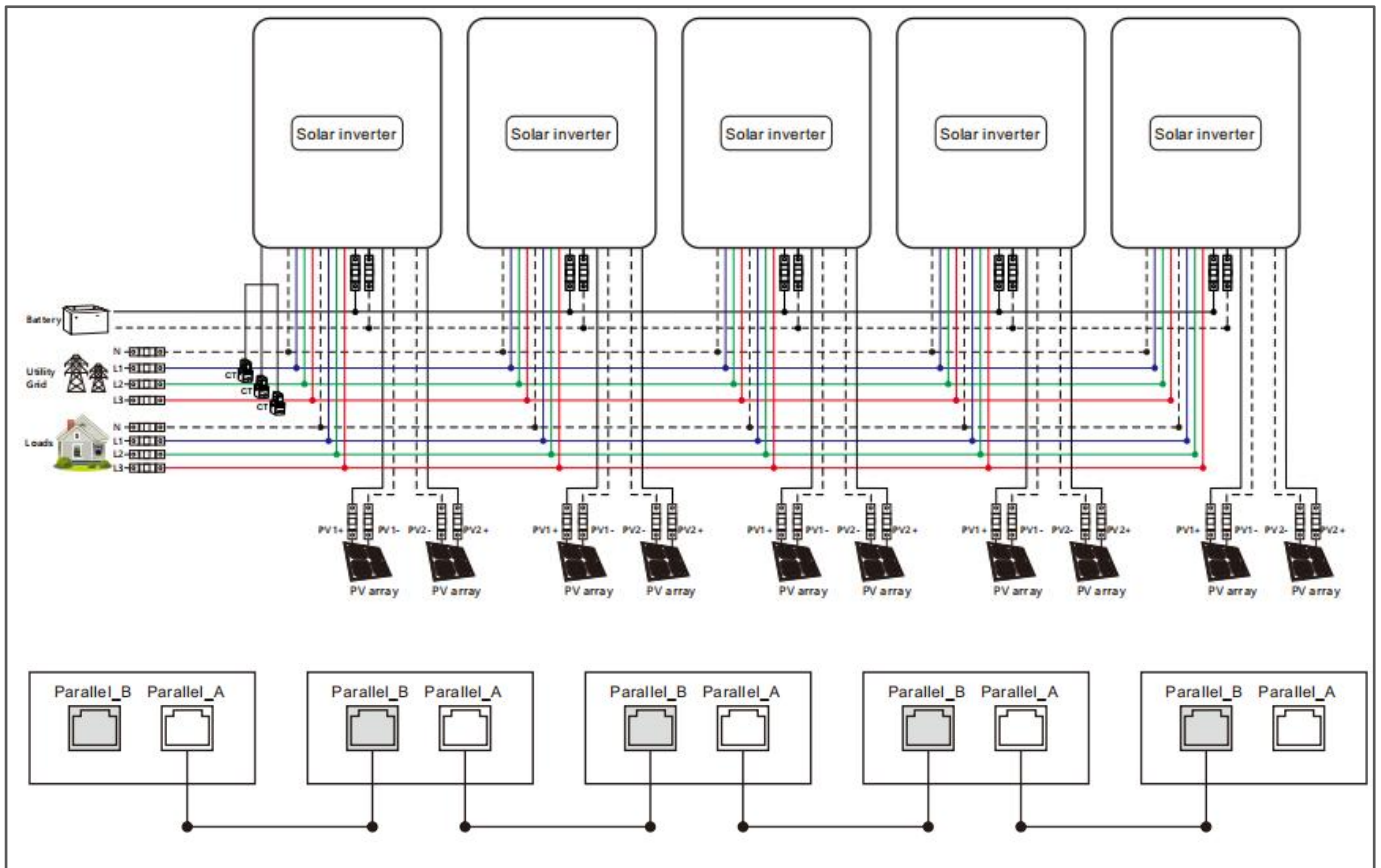

### D. Five units connected in parallel:



### E. Six units connected in parallel:

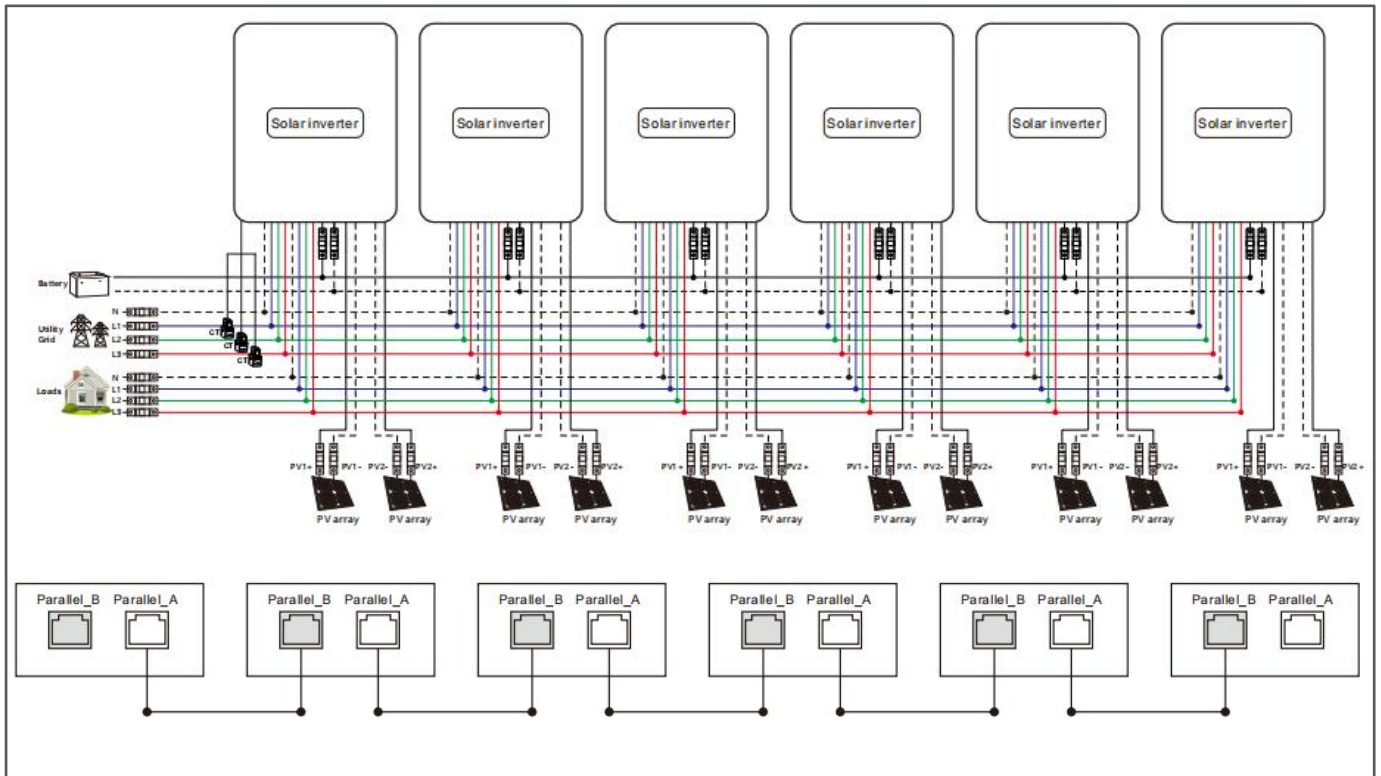



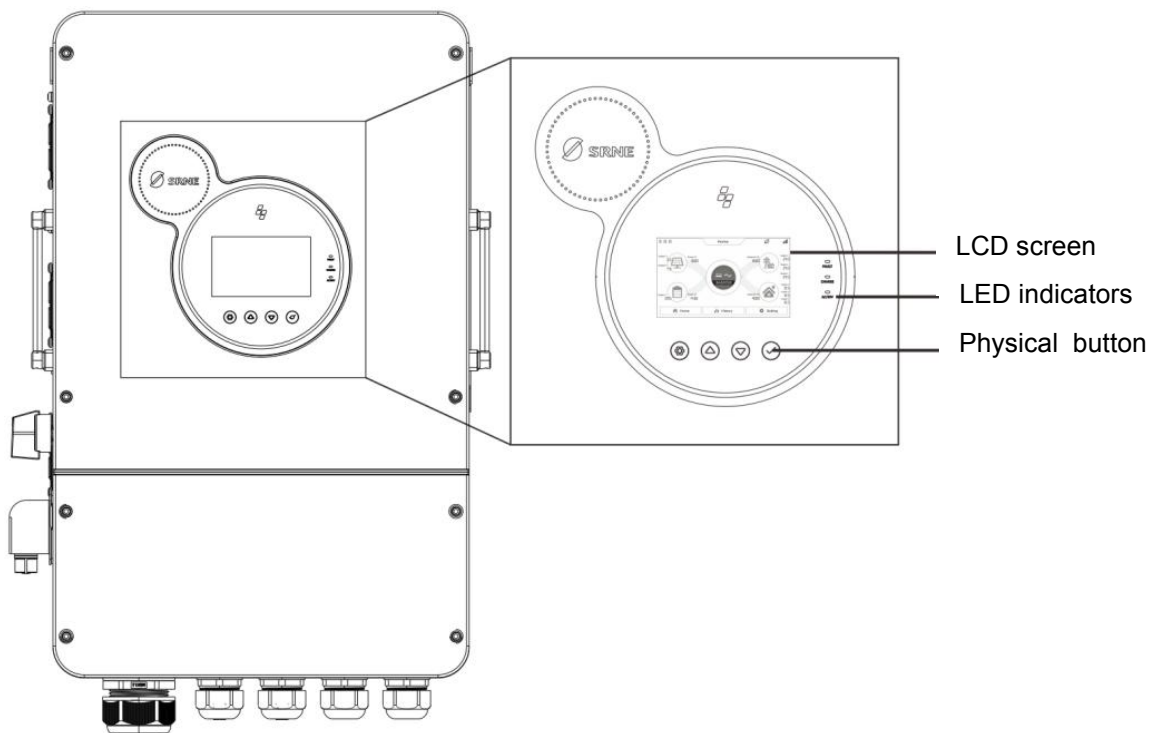

## 5. Operation

### 5.1 Operation and display panel

The operation and display panel below includes 1 LCD screen, 3 indicators, 4 Physical button.



## ■ Physical button







| Physical button   | Description                                      |
|---|--|
|  | To enter/exit the setting menu                   |
|  | Go to the next option                            |
|  | Go to the previous option                        |
|  | Confirm/Enter the selection in the settings menu |







## ■ LED indicators

| Indicators | Color  | Description                            |
|------------|--------|--|
| FAULT      | Red    | Continued: Level 1 fault               |
|            |        | Flash: Level 2 fault                   |
| CHARGE     | Green  | Continued: charging complete           |
|            |        | Flash: charging                        |
| AC/INV     | Yellow | Continued: utility grid by-pass output |
|            |        | Flash: inverter output                 |

## ■ Display screen



| Icon  | Description | Icon  | Description               |
|---|-------------|---|---------------------------|
|  | Solar panel |  | Load                      |
|  | Battery     |  | Grid or Generator         |
|  | Home page   |  | Inverter operating status |

|   |                                       |   |  |
|---|---------------------------------------|---|--|
|  History | Historical data                       |  Setting | Setting  |
| 0 : 0 : 0   | Local time                            |          | Buzzer Off   |
|          | Energy saving mode                    |          | Power flow direction   |
| <b>Monday</b>   | Weekday                               | <b>UPS</b>  | UPS load<br>(Connected to the load terminal of the inverter) |
| <b>HOME</b>   | HOME Load<br>(Connected to GRID Side) |          | Generator port   |

■ **View real-time data**

On the LCD home screen, click the inverter icon, battery icon, mains icon, load icon and photovoltaic icon to view the real-time data of the machine.

| System Data  |                            |     |                        |
|--------------|----------------------------|-----|------------------------|
| No.          | Real - time data items     | No. | Real - time data items |
| 1            | Device Information         | 2   | Serial Number          |
| 3            | Software Version           | 4   | Minor Version          |
| 5            | LCD Version                | 6   | Power Rating           |
| 7            | MCU2 Version               | 8   | RS485 Address          |
| 9            | Customer ID                | 10  | External Temperature   |
| 11           | Inverter Temperature       | 12  | PV Temperature         |
| 13           | Transformer Temperature    | 14  | L1 Voltage             |
| 15           | L1 Current                 | 16  | L2 Voltage             |
| 17           | L2 Current                 | 28  | L3 Voltage             |
| 19           | L3 Current                 | 20  | Positive Bus Voltage   |
| 21           | Negative Bus Voltage       | 22  | Total Bus Voltage      |
| Battery Data |                            |     |                        |
| 1            | Battery SOH %              | 2   | Battery SOC %          |
| 3            | Battery Voltage            | 4   | Charge Current         |
| 5            | Battery Power              | 6   | Discharge Current      |
| 7            | BMS Communication Protocol | 8   | Battery Type           |
| 9            | Charging Status            |     |                        |
| Grid Data    |                            |     |                        |
| 1            | L1 Voltage                 | 2   | L1 Current             |
| 3            | L1 Active Power            | 4   | L1 Apparent Power      |
| 5            | L3 Voltage                 | 6   | L3 Current             |
| 7            | Frequency                  | 8   | L2 Voltage             |
| 9            | L2 Current                 | 10  | L2 Active Power        |
| 11           | L2 Apparent Power          | 12  | L3 Active Power        |

|                  |                                    |    |                                  |
|------------------|------------------------------------|----|----------------------------------|
| 13               | L3 Apparent Vower                  | 14 | Grid Charging Current            |
| <b>Load Data</b> |                                    |    |                                  |
| 1                | L1 Voltage                         | 2  | L1 Current                       |
| 3                | L1 Active Vower                    | 4  | L1 Apparent Power                |
| 5                | L1 Frequency                       | 6  | L1 Load Factor                   |
| 7                | L1 Domestic Load Vower             | 8  | L1 Secondary Load Apparent Power |
| 9                | Overall Load Rate of the Equipment | 10 | L2 Voltage                       |
| 11               | L2 Current                         | 12 | L2 Active Power                  |
| 13               | L2 Apparent Power                  | 14 | L2 Frequency                     |
| 15               | L2 Load Factor                     | 16 | L2 Domestic Load Power           |
| 17               | L2 Total Secondary Load Power      | 18 | Overall Load Factor              |
| 19               | L3 Voltage                         | 20 | L3 Current                       |
| 21               | L3 Active Vower                    | 22 | L3 Apparent Power                |
| 23               | L3 Frequency                       | 24 | L3 Load Factor                   |
| 25               | L3 Domestic Load Power             | 26 | L3 Total Secondary Load Power    |
| 27               | Load Ratio of the Whole Machine    | 28 | L1 Secondary Load Current        |
| 29               | L1 Secondary Load Active Power     | 30 | L1 Secondary Load Apparent Power |
| 31               | L2 Secondary Load Current          | 32 | L2 Secondary Load Active Power   |
| 33               | L2 Secondary Load Apparent Power   | 34 | L3 Secondary Load Current        |
| 35               | L3 Secondary Load Active Power     | 36 | L3 secondary Load Apparent power |
| <b>PV Data</b>   |                                    |    |                                  |
| 1                | PV1 Voltage                        | 2  | PV1 Current                      |
| 3                | PV1 Power                          | 4  | PV2 Voltage                      |
| 5                | PV2 Current                        | 6  | PV2 Power                        |
| 7                | PV Total Power                     |    |                                  |

Click on 'History' to see the history of the machine.

|                          |  |   |  |
|--------------------------|--|---|--|
| <b>Today's Data</b>      |  |   |  |
| 1                        | Battery Charging Amount                  | 6 | Load Consumption                                 |
| 2                        | Battery Discharging Amount               | 7 | Grid Charging Amount                             |
| 3                        | Battery Discharging Amount               | 8 | Load consumption from the utility Power supply   |
| 4                        | Today's Grid-connected Power Amount      | 9 | Load capacity of the Generator                   |
| 5                        | Generator charging amount                |   |  |
| <b>Historical Data</b>   |  |   |  |
| 1                        | Last seven days PV Power Generation      | 4 | Grid Charge for the Last Seven Days              |
| 2                        | Battery Charging in the Last Seven Days  | 5 | Load Consumption in the Last Seven Days          |
| 3                        | Battery Discharge in the Last Seven Days | 6 | Consumption From the Grid in the Last Seven Days |
| <b>Energy Statistics</b> |  |   |  |

|                            |                              |   |                                      |
|----------------------------|------------------------------|---|--------------------------------------|
| 1                          | Total Battery Charge         | 6 | Total Charging From the Grid         |
| 2                          | Total Solar Power Generation | 7 | Total Load Consumption From the Grid |
| 3                          | Total Battery Discharge      | 8 | Total Grid Connection                |
| 4                          | Total Load Consumption       | 9 | Total Generator Carrying Capacity    |
| 5                          | Total Generator Charge       |   |                                      |
| <b>Historical Failures</b> |                              |   |                                      |

## 5.2 Setting

**Operation Instructions:** Click "Settings" in the menu bar at the bottom of the screen to enter the settings interface. It includes five categories of settings: Basic Setup, Work Mode Setup, Battery Setup, On grid Setup, and Advance Setup.

### 5.2.1 Work mode setup

#### 5.2.1.1 Work mode

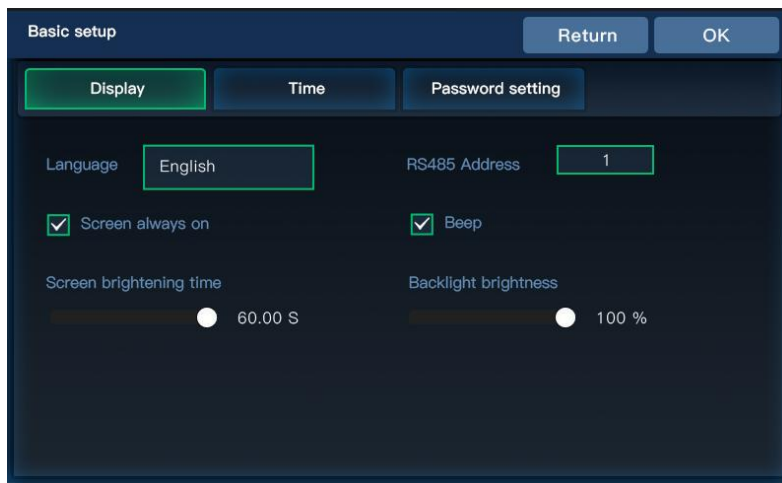

| Parameter Meaning       | Description  |
|-------------------------|--|
| Language                | English, Italia, German, Spanish, Chinese, Polski  |
| RS485 Address           | This refers to the RS485 address of the inverter. For a single unit, the adjustable range is 1~254, and for parallel units, it is 1~ 6 |
| Screen always on        | Selectable whether the screen is always on or not.   |
| Beep                    | You can choice whether enable the Beep alarm.  |
| Screen brightening time | Setting range 0 ~ 60 seconds.  |
| Backlight brightness    | 0~100%   |

## 5.2.1.2 Time setup

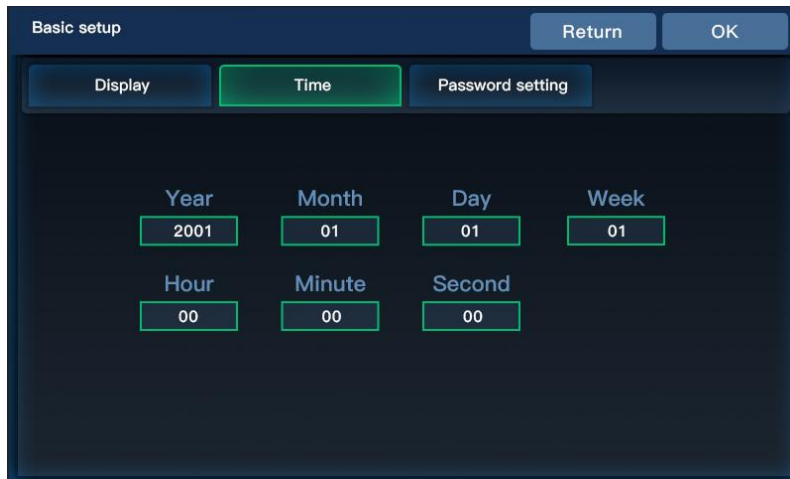

Basic setup Return OK

Display **Time** Password setting

Year: 2001 Month: 01 Day: 01 Week: 01

Hour: 00 Minute: 00 Second: 00

## 5.2.1.3 Password setting ( Password is required to access the Grid Settings and Advanced Settings )

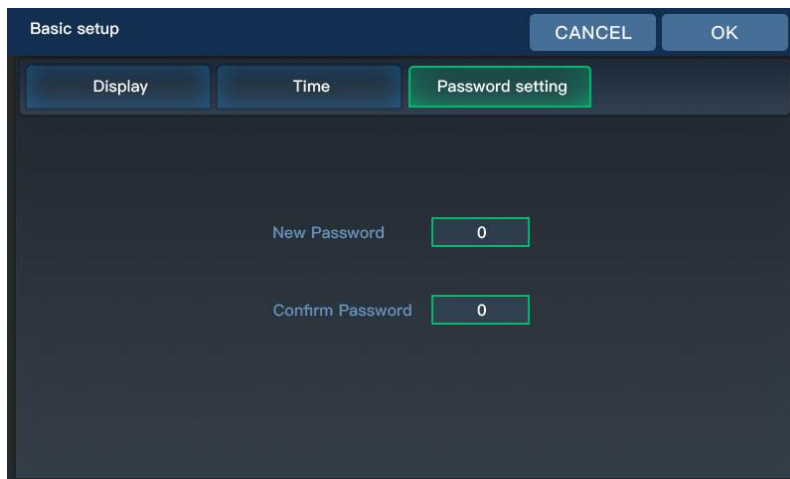

Basic setup CANCEL OK

Display Time **Password setting**

New Password: 0

Confirm Password: 0

- Default password is "4321".
- Password setting value range: 0~9999

## 5.2.2 Work mode setup

### 5.2.2.1 Work mode



Work mode setup Return OK

**Work mode** Peak shaving

Hybrid grid mode  Grid charging enable

On grid **Battery energy manage**

Limit power to ups load  Standby

Limit power to home load  Battery to ups load

AC Coupling  Battery to home load

PV energy manage  Battery to grid sell

First to load

First to charging

First to grid

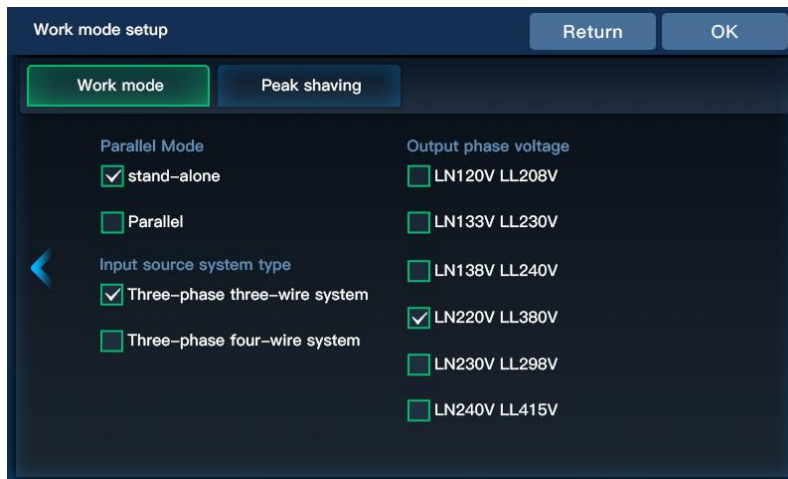

- **Home Load:** connected to the GRID port of the machine, requires external CT for monitoring.
- **UPS Load:** connected to the LOAD port of the machine.

| Parameter Meaning     | Option   | Description  |
|-----------------------|--|--|
| Hybrid grid mode      | On grid  | PV and battery energy can be grid-connected  |
|                       | Limit power to ups load  | UPS Load Backflow Prevention, PV or Battery Energy for UPS Load Only, Excess Energy Charging.  |
|                       | Limit power to home load   | Home Load backflow prevention, PV or battery energy is for Home loads only, excess energy is not connected to the grid.                  |
|                       | AC Coupling  | Enable AC coupling function.   |
| PV energy manage      | When the hybrid grid mode is set to "Limit Power to ups" or CT is not connected, the following loads are UPS loads.<br>When the hybrid grid mode is set to "Limit Power to home/On grid" and CT is connected, the following loads are UPS loads plus home loads. |  |
|                       | First to Load  | PV Energy Supply Priority: Load-Charge-Grid Connection.  |
|                       | First to charging  | PV Energy Supply Priority: Charge - Load - Grid Connection.  |
|                       | First to grid  | PV Energy Supply Priority: Load - Grid Connection - Charging.  |
| Grid charging enable  | Selectable grid participation in battery charging.   |  |
| Battery energy manage | Standby  | Batteries are not discharged in the presence of utility power, and are inverted and discharged only in the off-grid operating condition. |
|                       | Battery to UPS loads   | When the PV power is less than the UPS load power, the battery discharges to replenish it.   |
|                       | Battery to home load   | The battery can supply power to household loads and UPS loads.   |
|                       | Battery to grid sell   | Battery can supply power to the grid.  |
| Parallel Mode         | Stand-alone  |  |
|                       | Parallel   |  |

|                          |  |                     |
|--------------------------|--|---------------------|
| Input source system type | Three-phase three-wire system  | Without N-wire mode |
|                          | Three-phase four-wire system   | With N-wire mode    |
| Output Phase Voltage     | Settable : LN120V LL208V , LN133V LL230V, LN138V LL240V, LN220V LL380V, LN230V LL298V, LN240V LL415V |                     |

### 5.2.2.2 Peak shaving

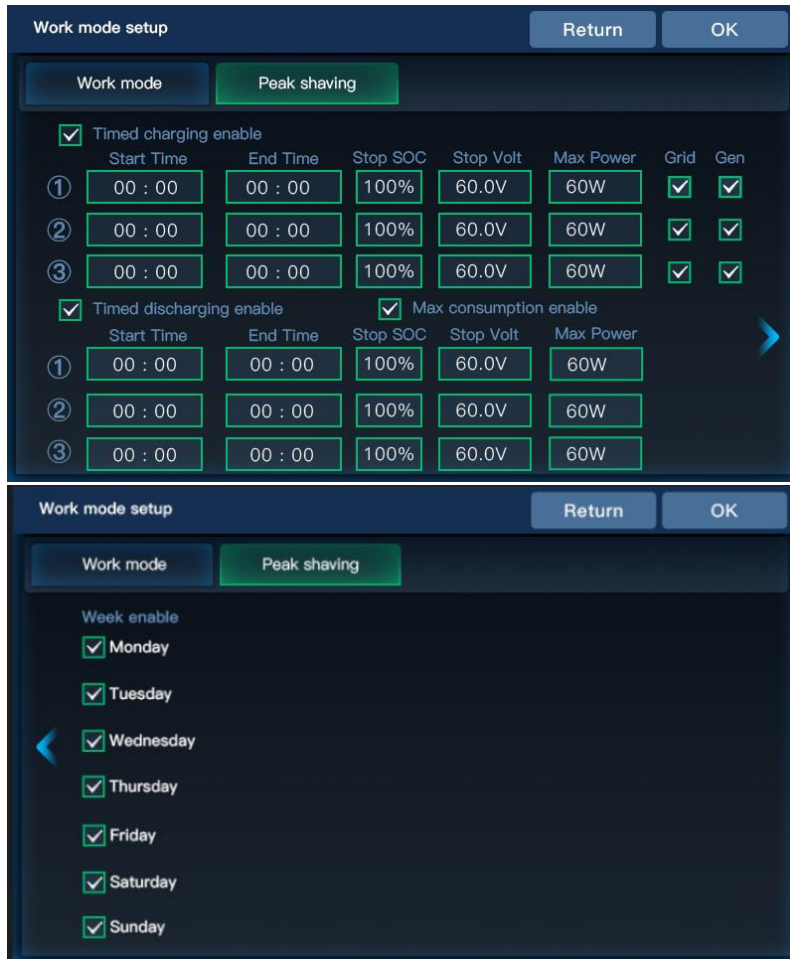

| Parameter Meaning                 | Description   |
|-----------------------------------|---|
| Time charging/ discharging enable | Select whether to turn on timed charging and discharging.   |
| Max. consumption enable           | When this option is enabled, the battery operates according to the battery energy management settings during non-timed charge-discharge periods.                                    |
| Start/End Time                    | Setting the time period for timed charging and discharging.   |
| Stop SOC                          | Setting the battery charging cut-off SOC value and the cut-off SOC value for discharging during the timed charging and discharging time period (during BMS communication).          |
| Stop Volt.                        | Setting the battery charging cut-off voltage value and discharging cut-off voltage value during the timed charging and discharging time period (when the BMS is not communicating). |
| Max. Power                        | Setting the battery charging power and discharging power during the timed charging and discharging time period.   |

|             |   |
|-------------|---|
| Grid        | When setting the timed charge, select the grid to charge the battery.   |
| Gen         | When setting the timed charge, select the generator to charge the battery.                                      |
| Week enable | Sets the day of the week for timed charging/discharging (effective only for time-sharing charging/discharging). |

## 5.2.3 Battery setup

To enter this setting, you need to enter the password set by the user, the default password is "4321" .

### 5.2.3.1 Battery type

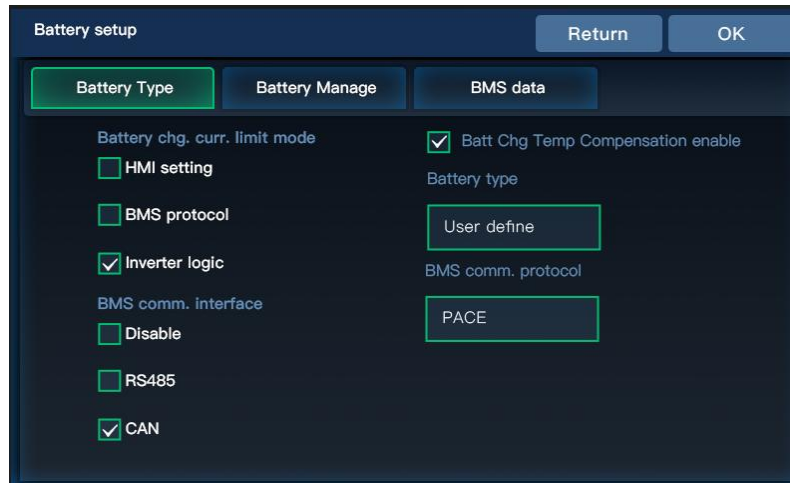

| Parameter Meaning                 | Option      | Description   |
|-----------------------------------|-------------|---|
| Battery chg. curr. limit mode     | HMI         | Maximum battery charging current is limited according to the inverter battery charging current setting value.   |
|                                   | BMS         | Maximum battery charging current is limited by the current limit value of the BMS.  |
|                                   | Inverter    | Maximum battery charging current is limited by the machine's derating logic.  |
| BMS comm. interface               | Disable     | BMS does not communication.   |
|                                   | RS485       | BMS RS485 communication function.   |
|                                   | CAN         | BMS CAN communication function.   |
| Batt Chg Temp Compensation enable |             | Select whether to turn on temperature compensation.   |
| BMS comm. protocol                |             | When the BMS port selection setting item = 485 or CAN, it is necessary to select the corresponding lithium battery manufacturer brand for communication:<br>485 protocol: 1: PACE 2: RUDA 3: AOGUAN 4: OULITE 5: CEF 6: XINWANGDA 7: DAQIN 8: WOW 9: PYL I 10: MIT 11: XIX 12: POL 13: GUOX 14: SMK 15: VOL 16: WES 17: SGP 18: GSL 19: PYT II<br>CAN protocol: 20: UZE 21: PYL 22: SGP 23: GSL |
| Battery Type                      | USER define | User customizable to set all battery parameters.  |
|                                   | SLD         | Sealed Lead Acid Battery.   |
|                                   | FLd         | Open-ended lead-acid batteries.   |
|                                   | GEL         | Gel Lead Acid Battery.  |
|                                   | LFP/14/ 15/ | Li-FePO4/14/15/16, corresponding to Li-FePO4 14 string, 15  |



|                                  |   |
|----------------------------------|---|
| Batt volt. restart dischg.       | When the battery voltage is too low to discharge, the battery voltage needs to reach this setting to discharge again.   |
| Battery under volt. alarm        | Battery under-voltage alarm point, when the battery voltage is lower than the judgment point, the under-voltage alarm will be reported and the output will not be turned off.   |
| Batt volt low recovery           | When the battery report voltage low fault, the battery voltage reach this setting, the fault will be cleared.   |
| Batt voltage low fault           | When in the off-grid state, the inverter will shut down due to the low voltage of the battery; when in the hybrid grid state, the battery will stop outputting due to low voltage.  |
| Battery max. curr. dischg.       | Set the max battery discharger current  |
| Batt. SOC stop dischg. in hybrid | In the hybrid grid state, the battery will stop discharging when the State of Charge (SOC) is lower than this set value. In the off-grid state, the battery will continue to discharge when the SOC is lower than this set value. |
| Batt. SOC restart dischg.        | When the battery report SOC low fault, the battery SOC reach this setting, it can restart discharge(valid when BMS communication is normal).  |

### 5.2.3.3 BMS data(When the battery communicate with inverter)

Check the data that battery BMS upload to inverter.



| Battery setup             |        |                          |       |          |  |
|---------------------------|--------|--------------------------|-------|----------|--|
| Battery Type              |        | Battery Manage           |       | BMS data |  |
| Battery Voltage:          | 33.3V  | Battery charge voltage:  | 33.3V |          |  |
| Battery Current:          | 33.3A  | Charge current limit:    | 33.3A |          |  |
| Battery Temp.:            | 33.3°C | Discharge current limit: | 33.3A |          |  |
| SOH:                      | 33%    | Battery rated capacity:  | 33AH  |          |  |
| Number of battery cycles: | 4444   | Battery remain capacity: | 33AH  |          |  |
| Alarms 1:                 | 50000  | Protection 1:            | 50000 |          |  |
| Alarms 2:                 | 50000  | Protection 2:            | 50000 |          |  |

### 5.2.4 On grid setup

To enter this setting, you need to enter the password set by the user, the default password is "4321" .

#### 5.2.4.1 Basic



| On grid setup  |  |   |        |   |       |   |  |
|----------------|--|---|--------|---|-------|---|--|
| Basic          |  | Enter Service   |        | Grid Protection   |       | Other   |  |
| Grid standard  | Not Initialized  | On Grid Reactive Power  | 0%     |   |       |   |  |
| Grid frequency | <input type="checkbox"/> 50Hz <input checked="" type="checkbox"/> 60Hz | <input checked="" type="checkbox"/> Reactive power over excited |        | <input type="checkbox"/> Reactive power under excited           |       |   |  |
| Sell Power Max | 6000W  | External CT ratio   | 2000:1 | On Grid PF  | 1.000 |   |  |
| Buy Power Max  | 6000W  | zero-export power   | 20W    | <input checked="" type="checkbox"/> Reactive power over excited |       | <input type="checkbox"/> Reactive power under excited |  |

| Parameter Meaning                   | Description   |
|-------------------------------------|---|
| Grid Standard                       | Europe: EN 50549-1  |
|                                     | German: VDE-AR-N 4105:2018  |
|                                     | Other area: GNL   |
|                                     | Austria: TE-OVE   |
|                                     | Thailand: PEA-MEA   |
| Grid frequency                      | Selection of local grid frequency, 50Hz/60Hz  |
| External CT ratio                   | When connecting an external CT, enter the ratio on the CT specification.  |
| Sell Power Max                      | Setting the maximum grid-connected power  |
| Buy Power Max                       | Maximum power drawn from the grid. If the grid charging power + load power exceeds this setting, the machine reduces the charging power.<br>(Setting range: 0 to rated power) |
| zero-export power                   | Error calibration power in the case of backflow prevention, recommended setting 20~100W   |
| On Grid Reactive Power              | Setting range 0~100%, % of reactive power   |
| Reactive power over / under excited | Over indicates 0-100% /<br>Under indicates -100% ~ 0%   |
| On Grid PF                          | Setting range 0.8~1   |
| Reactive power over / under excited | Over indicates 0.8~1 /<br>Under indicates -0.8 ~ -1   |

### 5.2.4.2 Parameters for the parallel connection (it is not recommended that the user change this recommendation)



| Parameter Meaning     | Description   |
|-----------------------|---|
| Enter service enable  | Grid connection startup setting (default is on), turn off the value of the inverter does not connect to the grid. |
| Connect Voltage Low   | Voltage less than this value will not be connected to the grid.   |
| Connect Frequency Low | Frequency less than this value will not connect to the grid.  |
| Connect Voltage High  | Voltage higher than this value does not connect to the grid.  |

|                                |  |
|--------------------------------|--|
| Connect Frequency High         | Frequency higher than this value will not be connected to the grid.    |
| Normal connect delay time      | Normal grid connection, grid connection delay time.                    |
| Normal Connect Power Ramp Rate | Normal grid connection, grid power rise rate.                          |
| Reconnect delay time           | Grid disconnection and reconnection, grid connection delay time.       |
| Reconnect Power Ramp Rate      | Grid disconnection reconnection, rate of rise of grid-connected power. |

### 5.2.4.3 Grid protection (it is not recommended that the user change this setting)



| Parameter Meaning | Description                             | Parameter Meaning | Description                            |
|-------------------|---|-------------------|--|
| LV1               | Class 1 undervoltage protection point   | HV1               | Class 1 overvoltage protection point   |
| LF1               | Class 1 underfrequency protection point | HF1               | Class 1 overfrequency protection point |
| LV2               | Class 2 undervoltage protection point   | HV2               | Class 2 overvoltage protection point   |
| LF2               | Class 2 underfrequency protection point | HF2               | Class 2 overfrequency protection point |
| Time              | Protection Response Time                |                   |  |

### 5.2.4.4 Other (it is not recommended that users change this setting)



| Parameter Meanin                 | Description   |
|----------------------------------|---|
| Frequency Droop (F-P) enable     | Adjustment of inverter output power according to grid frequency.              |
| Volt-Watt (V-P) curve enable     | Regulates the active power of the inverter according to the set grid voltage. |
| Volt-Var (V-Q) curve enable      | Adjustment of the inverter reactive power according to the set grid voltage.  |
| Watt-Var (P-Q) curve enable      | Adjustment of the inverter reactive power according to the set active power.  |
| Watt-PF (P-PF) curve enable      | Adjustment of the inverter power factor according to the set active power.    |
| LVRT/HVRT enable                 | Adjustment of the grid HV ride-through / LV ride-through values.              |
| Reactive power percentage enable |   |
| Discharge PF enable              |   |
| Charge PF enable                 |   |
| DRMS Enable                      | Australia only  |

## 5.2.5 Advance setup

To enter this setting, you need to enter the password set by the user, the default password is "4321" .

### 5.2.5.1 Generator

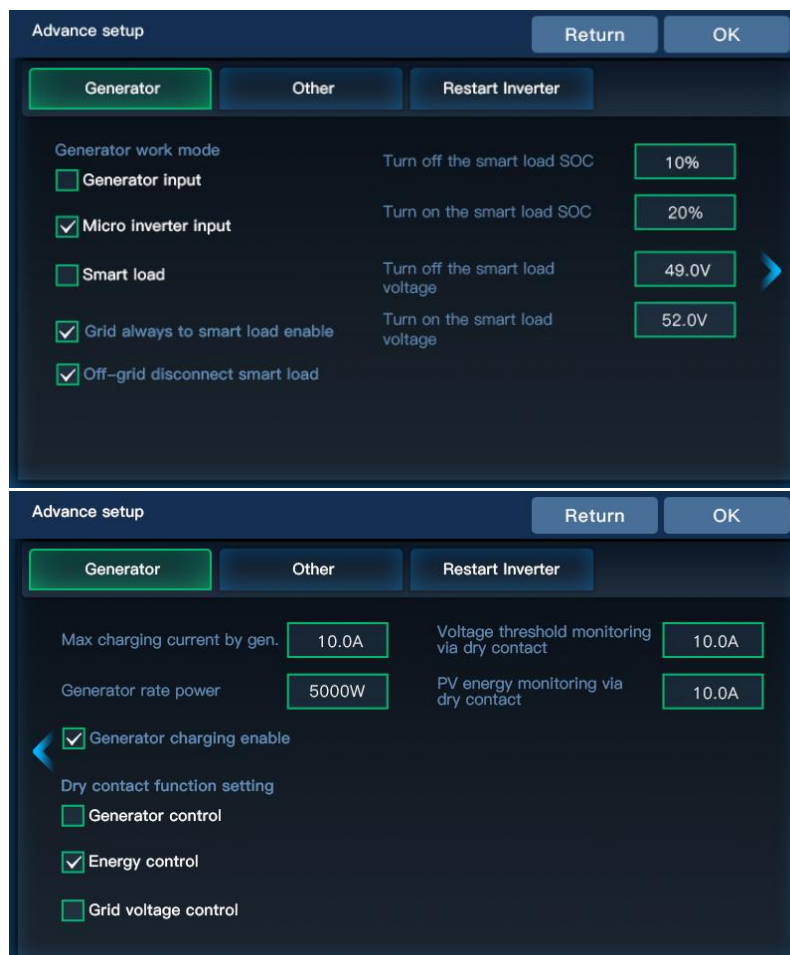

The screenshot shows the 'Advance setup' interface with the 'Generator' tab selected. The settings are as follows:

- Generator work mode:**
  - Generator input (Turn off the smart load SOC: 10%)
  - Micro inverter input (Turn on the smart load SOC: 20%)
  - Smart load (Turn off the smart load voltage: 49.0V)
  - Grid always to smart load enable (Turn on the smart load voltage: 52.0V)
  - Off-grid disconnect smart load
- Max charging current by gen.:** 10.0A
- Generator rate power:** 5000W
- Voltage threshold monitoring via dry contact:** 10.0A
- PV energy monitoring via dry contact:** 10.0A
- Generator charging enable
- Dry contact function setting:**
  - Generator control
  - Energy control
  - Grid voltage control

| Parameter Meaning   | Description  |   |
|---|--|---|
| Generator work mode   | Generator Input  | When the generator is connected to the "Gen port" , select the generator input.                             |
|   | Micro inverter input   | Grid-tie inverter is connected to the "Gen port" of the hybrid inverter.                                    |
|   | Smart load   | When a load is connected to the "Gen port" , select the load output.  |
| Grid always to smart load enable                                  | Whether to enable continuous power supply to the smart load.   |   |
| Off-grid disconnect smart load                                    | Immediate Disconnect Smart Load Setting Item in Off-Grid Mode.   |   |
| Turn off the smart load SOC<br>Turn on the smart load SOC         | Battery current SOC is less than 10% to turn off smart loads, greater than 20% to turn on smart loads.   |   |
| Turn off the smart load voltage<br>Turn on the smart load voltage | The current voltage of the battery is less than 49V to turn off the smart load, and more than 52V to turn on the smart load.                                       |   |
| Max charging current by gen.                                      | Maximum battery charging current of the generator.   |   |
| Generator rate power  | Setting the rated power of the generator.  |   |
| Generator charging enable   | Set whether the generator is charged or not.   |   |
| Dry contact function setting                                      | Generator control  | Control Generator Start/Stop  |
|   | Energy control   | When the PV grid-connected power exceeds the PV energy monitoring threshold, the dry contact activates.     |
|   | Grid voltage control   | When the grid voltage exceeds the dry contact monitoring grid voltage threshold, the dry contact activates. |
| Voltage threshold monitoring via dry contact                      | When the grid voltage exceeds this set value, the dry contact activates. When the voltage is 5V lower than this set value, the dry contact deactivates.            |   |
| PV energy monitoring via dry contact                              | When the PV grid-connected power exceeds this set value, the dry contact activates. When the power is 250W lower than this set value, the dry contact deactivates. |   |

## 5.2.5.2 Other

To enter this setting, you need to enter the password set by the user, the default password is "4321" .





| Parameter Meaning                     | Description  |
|---------------------------------------|--|
| PE-N Connect enable                   | Enable automatic switching of PE-N connections.  |
| PV Riso check enable                  | Enable PV insulation impedance detection.  |
| Leakage curr. protection enable       | Enable leakage current protection.   |
| BMS comm. error stop                  | Inverter stops output when BMS communication error occurs.   |
| Power saveing mode                    | After turning on the energy-saving mode, if the load is no load or less than 35W, the inverter output will be turned off after a delay of 5min; when the load is more than 50W, the inverter will start automatically. |
| MPPT scan                             | MTTP Global Scan Enable every 30 minutes.  |
| CT manual setting                     | Select the direction of the CT according to the installation of the CT.  |
| Load Type                             | Select the load type according to the connected load.  |
| Inverter Current Limiting coefficient | Adjust the current coefficient when the inverter is soft-started (this setting is not recommended to be modified by the customer).   |
| Electric meter options                | Whether to enable three-phase meter.   |
| Smart meter connect point             | Select on-grid inverter side or grid side according to meter installation location.  |

### 5.2.5.3 Restart

To enter this setting, you need to enter the password set by the user, the default password is "4321" .

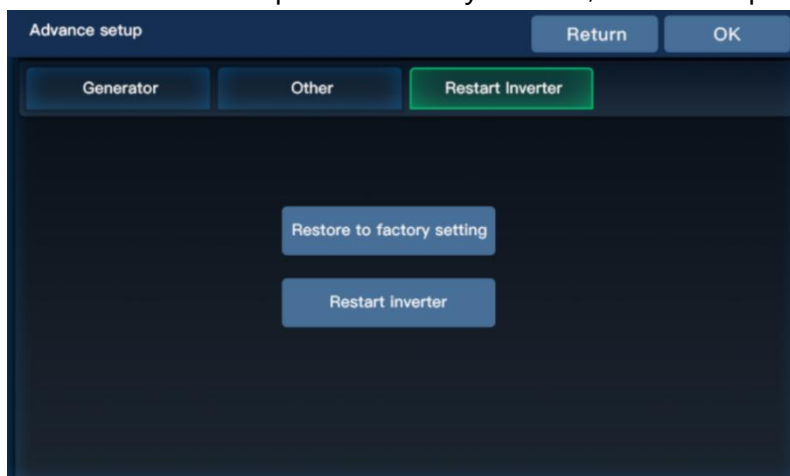

- **Restore to factory settings:** Reset all inverter settings.
- **Restart inverter:** Restart the inverter.

## 5.3 Charging/discharging function by days of the week and time of the day

The HESP series, including HESP4830SH3 to HESP4870SH3 and the HESP4880SHD3 series, have the function of charging and discharging by different time periods within a week, distinguishing between Monday and Sunday. Users can set different charging and discharging time periods according to the local peak and valley electricity prices, so as to make rational use of the utility power and photovoltaic energy. When the utility power price is expensive, the battery inverter can be used to supply electricity to the load. When the utility power price is low, the utility power can be used to supply power to the load and charge the battery, which can help users save electricity bills to the greatest extent.

Users can turn on/off the time-period-based charging/discharging function in the parameters of "Segmented Charging Enable" and "Segmented Discharging Enable" in the setting menu. And set the charging and discharging time periods in the parameters of "Timed Utility Power Charging Start/Time Setting" and "Timed Utility Power Discharging Start/Time Setting".

**Peak-Valley Electricity Tariff**

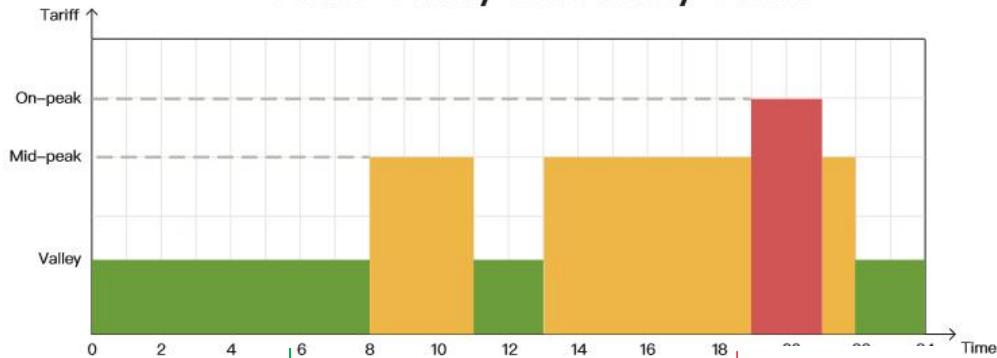

**Weekly and hourly mains charging, with load function**



There are 7 weekdays and 3 time slots that can be set by the user. The user can set the grid charging/loading time slots within the range of 00:00 to 23:59 from Monday to Sunday, and if there is PV energy output during the time slots set by the user, PV energy will be utilized in priority, and if there is no PV energy output or insufficient PV energy, the grid will be activated as a supplementary power.

**Battery discharging function by days of the week and time periods**



There are seven self-defined days of the week and three definable time slots. Users can set the battery discharge time within the range of 00:00 to 23:59 from Monday to Sunday, and the inverter will prioritize the battery inverter to carry the load during the time slots set by the user, and if the battery is insufficient, the inverter will automatically switch to the mains to ensure the loads are running stably.

## 5.4 Battery parameter

### ■ Lead-acid Battery

| Battery type<br>Parameters                       | Sealed lead acid battery (SLD)  | Gel lead acid battery (GEL) | Flooded lead acid battery (FLD) | User-defined (USE) | Adjustable |
|--|---------------------------------|-----------------------------|---------------------------------|--------------------|------------|
| Overvoltage disconnection voltage                | 60V                             | 60V                         | 60V                             | 60V                |            |
| Battery fully charged recovery point             | 52V                             | 52V                         | 52V                             | 52V                | √          |
| Boost charge voltage                             | -                               | -                           | -                               | 40 ~ 58.4V         | √          |
| Undervoltage alarm voltage                       | 44V                             | 44V                         | 44V                             | 40 ~ 52.2V         | √          |
| Undervoltage alarm voltage recovery point        | Undervoltage alarm voltage+0.8V |                             |                                 |                    |            |
| Low voltage disconnection voltage                | 42V                             | 42V                         | 42V                             | 40 ~ 60V           | √          |
| Low voltage disconnection voltage recovery point | 52V                             | 52V                         | 52V                             | 52V                | √          |
| Discharge limit voltage                          | -                               | -                           | -                               | 40 ~ 60V           | √          |
| Over-discharge delay time                        | 5s                              | 5s                          | 5s                              | 1 ~ 30s            | √          |
| Boost charge duration                            | -                               | -                           | -                               | 10 ~ 900 minutes   | √          |

### ■ Li-ion Battery

| Battery type<br>Parameters                            | Ternary (N13)                   | Ternary (N14) | LFP (L16) | LFP (L15) | LFP (L14) | Adjustable |
|---|---------------------------------|---------------|-----------|-----------|-----------|------------|
| Overvoltage disconnection voltage                     | 60V                             | 60V           | 60V       | 60V       | 60V       |            |
| Battery fully charged recovery point                  | 50.4V                           | 54.8V         | 53.6V     | 50.4V     | 47.6V     | √          |
| Equalizing charge voltage                             | -                               | -             | -         | -         | -         | √          |
| Boost charge voltage                                  | 53.2V                           | 57.6V         | 56.8V     | 53.2V     | 49.2V     | √          |
| Undervoltage alarm voltage([01] fault)                | 43.6V                           | 46.8V         | 49.6V     | 46.4V     | 43.2V     | √          |
| Undervoltage alarm voltage recovery point([01] fault) | Undervoltage alarm voltage+0.8V |               |           |           |           |            |

|  |             |             |             |             |             |   |
|--|-------------|-------------|-------------|-------------|-------------|---|
| Low voltage disconnection voltage([04] fault)  | 38.8V       | 42V         | 48.8V       | 45.6V       | 42V         | √ |
| Low voltage disconnection voltage recovery point ([04] fault)(setup item [batt.volt.low fault recovery]) | 46V         | 49.6V       | 52.8V       | 49.6V       | 46V         | √ |
| Discharge limit voltage  | 36.4V       | 39.2V       | 46.4V       | 43.6V       | 40.8V       | √ |
| Over-discharge delay time  | 30s         | 30s         | 30s         | 30s         | 30s         | √ |
| Boost charge duration  | 120 minutes | 120 minutes | 120 minutes | 120 minutes | 120 minutes | √ |

# 6.Communication

## 6.1 Overview

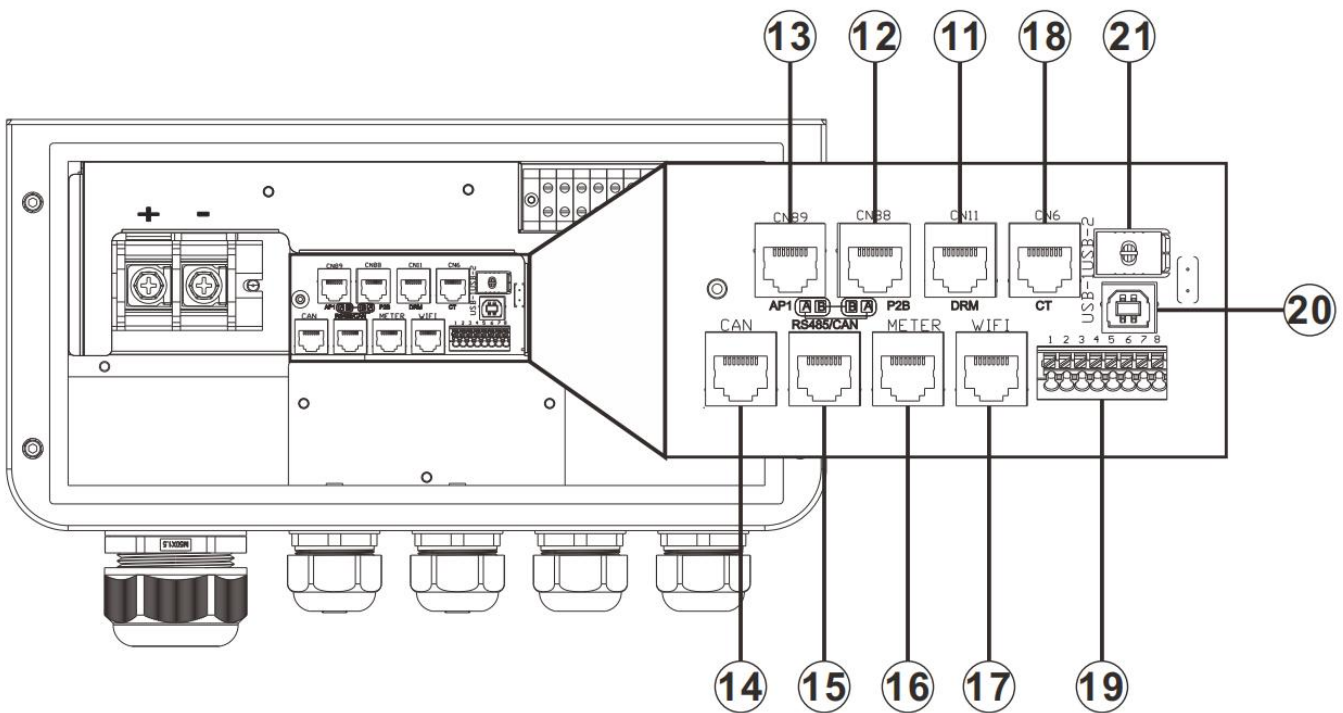

|    |                               |    |                               |
|----|-------------------------------|----|-------------------------------|
| 11 | DRMS port                     | 12 | Parallel communication port B |
| 13 | Parallel communication port A | 14 | CAN communication port        |
| 15 | 485 communication port        | 16 | Meter port                    |
| 17 | WIFI port                     | 18 | CT port                       |
| 19 | Dry contact                   | 20 | USB-1 port                    |
| 21 | USB-2 port                    |    |                               |

## 6.2 USB-1 port

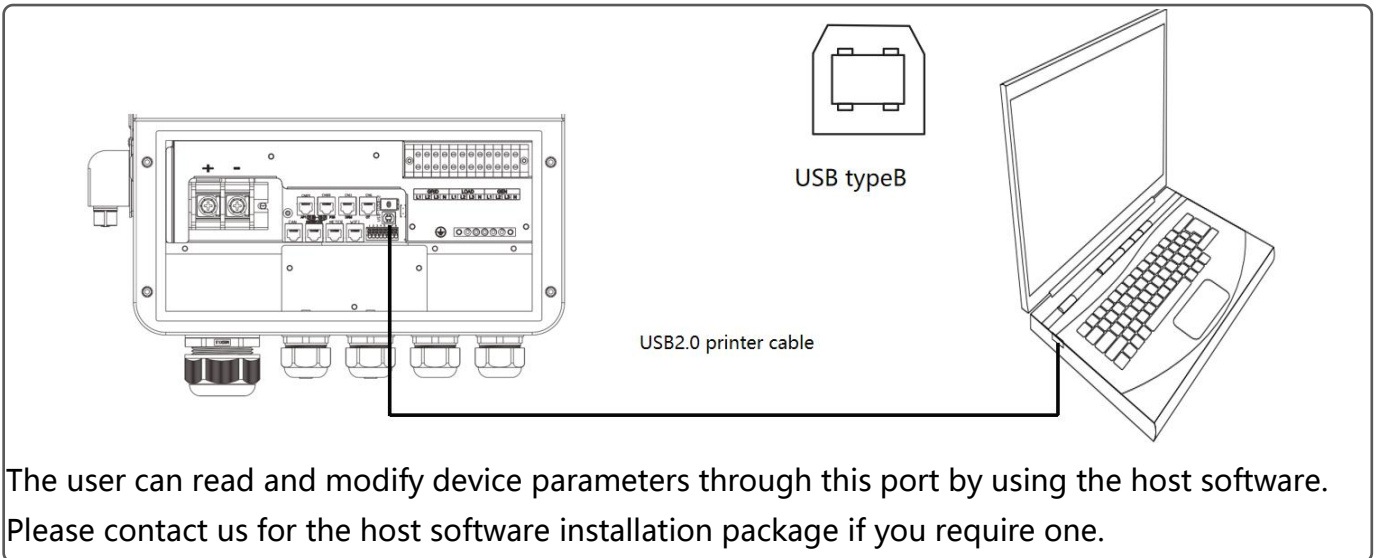

## 6.3 WIFI port

WIFI communication port can be connected with our self-developed RS485 to WIFI/GPRS communication module, which can be connected to our inverter to check the operation parameters and status of the inverter through mobile APP.

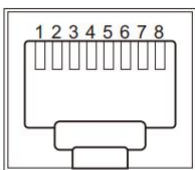
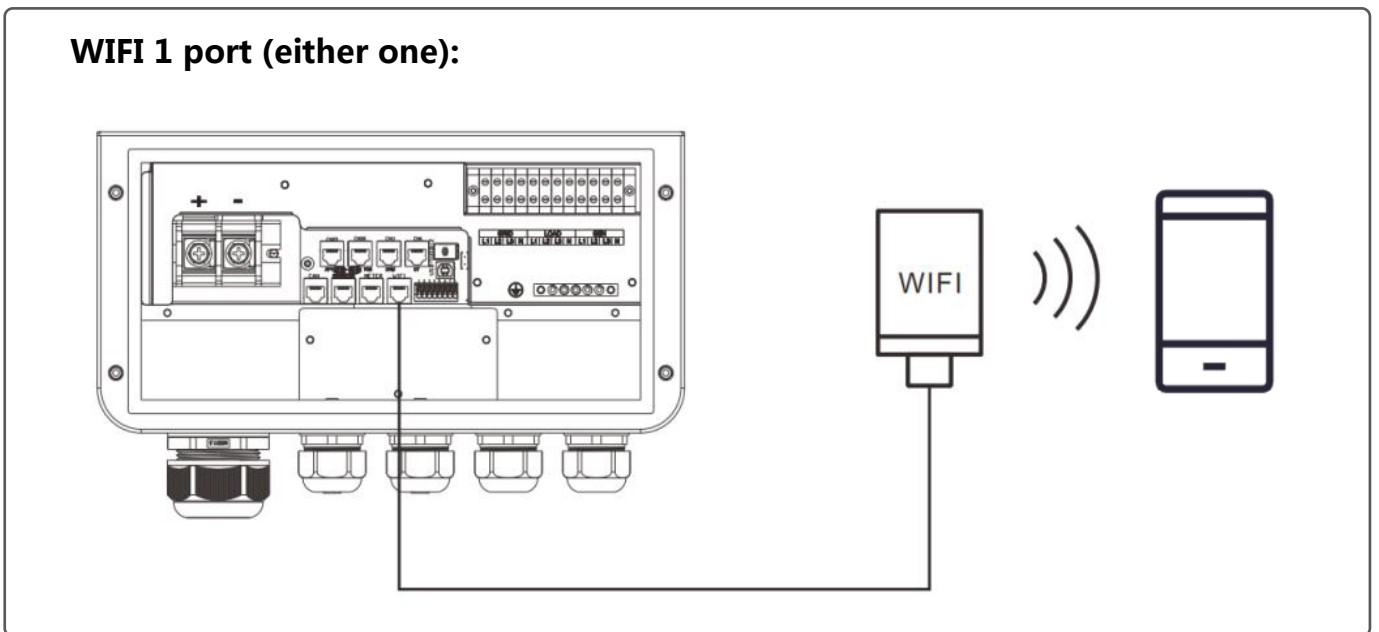

WIFI

| <b>RJ45</b>       | Pin 1 | Pin 2 | Pin 3 | Pin 4 | Pin 5 | Pin 6 | Pin 7   | Pin 8   |
|-------------------|-------|-------|-------|-------|-------|-------|---------|---------|
| <b>Definition</b> | 5V    | GND   | /     | /     | /     | /     | RS485-A | RS485-B |

## WiFi 2 ports (choose one of the two):

HESP4850SH3 ~ HESP4870SH3 , HESP4880SHD3

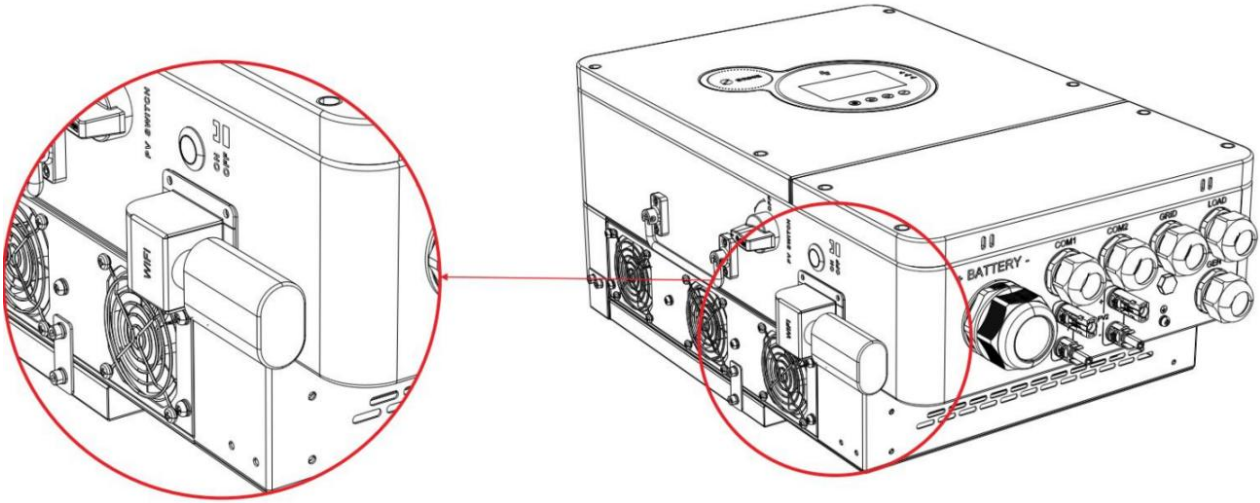

HESP4830SH3 ~ HESP4840SH3

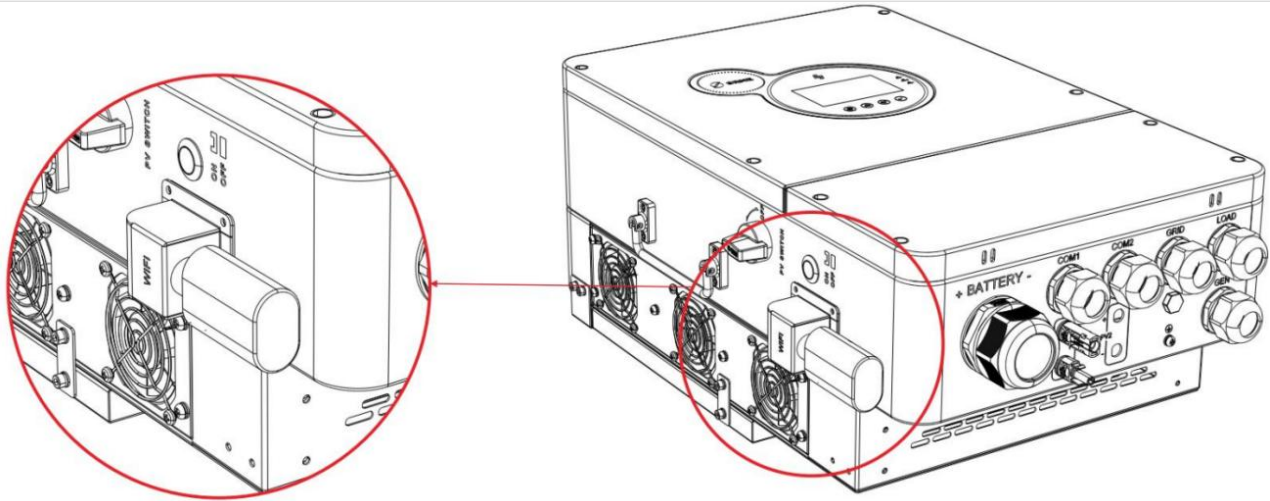

## 6.4 RS485 port

The RS485/CAN interface is used to connect to the BMS lithium battery.

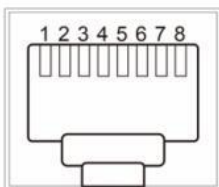

RS485

| <b>RJ45</b>       | Pin 1   | Pin 2   | Pin 3 | Pin 4 | Pin 5 | Pin 6 | Pin 7   | Pin 8   |
|-------------------|---------|---------|-------|-------|-------|-------|---------|---------|
| <b>Definition</b> | RS485-B | RS485-A | /     | CANH  | CANL  | /     | RS485-A | RS485-B |

### NOTICE

If you need to use the inverter to communicate with the lithium battery BMS, please contact us for the communication protocol or upgrade the inverter to the appropriate software programme.

## 6.5 CAN port

The CAN port is used to connect to the BMS of Liion battery .

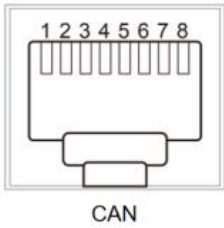

| <b>RJ45</b>       | Pin 1 | Pin 2 | Pin 3 | Pin 4 | Pin 5 | Pin 6 | Pin 7 | Pin 8 |
|-------------------|-------|-------|-------|-------|-------|-------|-------|-------|
| <b>Definition</b> | /     | /     | /     | CANH  | CANL  | /     | /     | /     |

## 6.6 USB-2 port

It is used to updated the screen firmware.

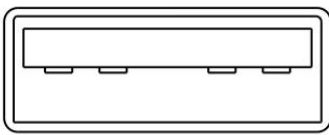

## 6.7 DRMS(Only Australia)

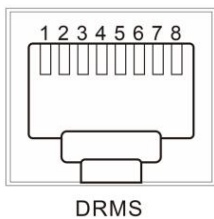

| <b>RJ45</b>       | Pin 1 | Pin 2 | Pin 3 | Pin 4 | Pin 5  | Pin 6        | Pin 7 | Pin 8 |
|-------------------|-------|-------|-------|-------|--------|--------------|-------|-------|
| <b>Definition</b> | DRM5  | DRM6  | DRM7  | DRM8  | RefGen | COM/<br>DRM0 | V+    | V-    |

| <b>MODEL</b> | <b>RJ45 socket asserted by shorting pins</b> |   | <b>Requirement</b>  |
|--------------|--|---|---|
|              |  |   |   |
| DRM0         | 5  | 6 | Operate the disconnection device.   |
| DRM5         | 1  | 5 | Do not generate power to grid.  |
| DRM6         | 2  | 5 | Do not generate at more than 50% of rated power.                                    |
| DRM7         | 3  | 5 | Do not generate at more than 75% of rated power AND Sink reactive power if capable. |
| DRM8         | 4  | 5 | Increase power generation (subject to constraints from other active DRMs) .         |

## 6.8 External CT wiring (CT direction pointing toward the inverter)

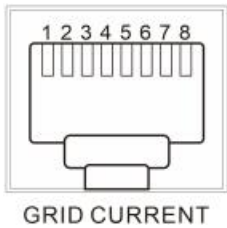
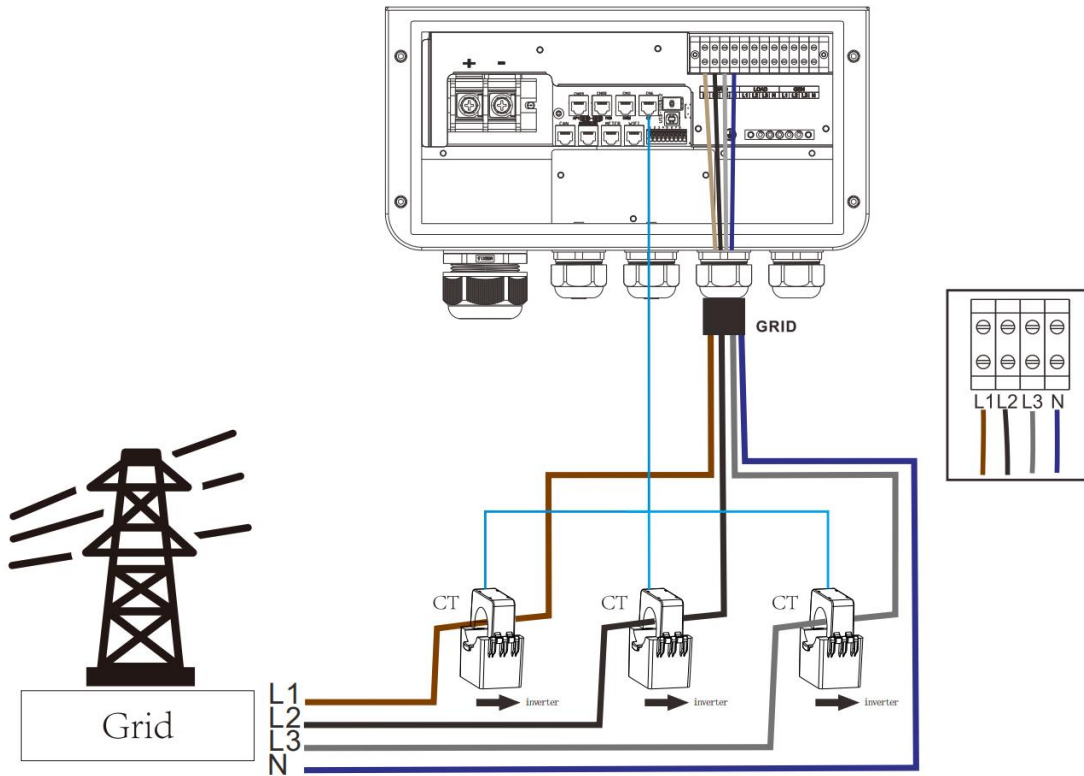

| RJ45              | Pin 1 | Pin 2 | Pin 3 | Pin 4 | Pin 5 | Pin 6 | Pin 7 | Pin 8 |
|-------------------|-------|-------|-------|-------|-------|-------|-------|-------|
| <b>Definition</b> | CT1+  | CT1-  | /     | CT2+  | CT2-  | /     | CT3+  | CT3-  |

Split Core Current Transformer (CT) dimension: (mm)

Secondary output cable length is 4m.

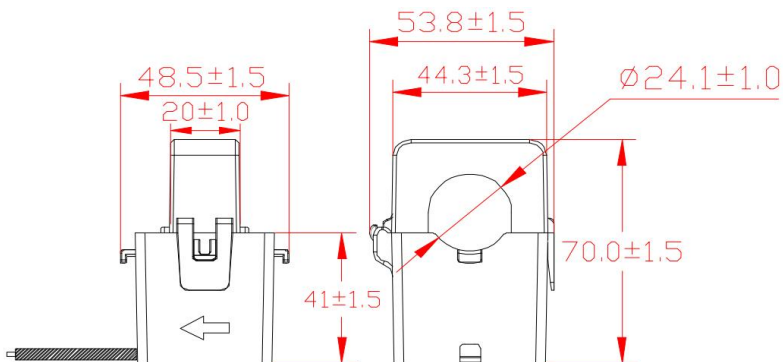

## 6.9 Three-phase meter wiring (CT direction pointing towards the grid)(Optional)

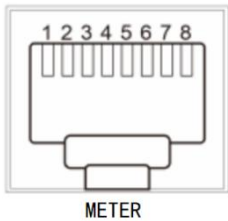
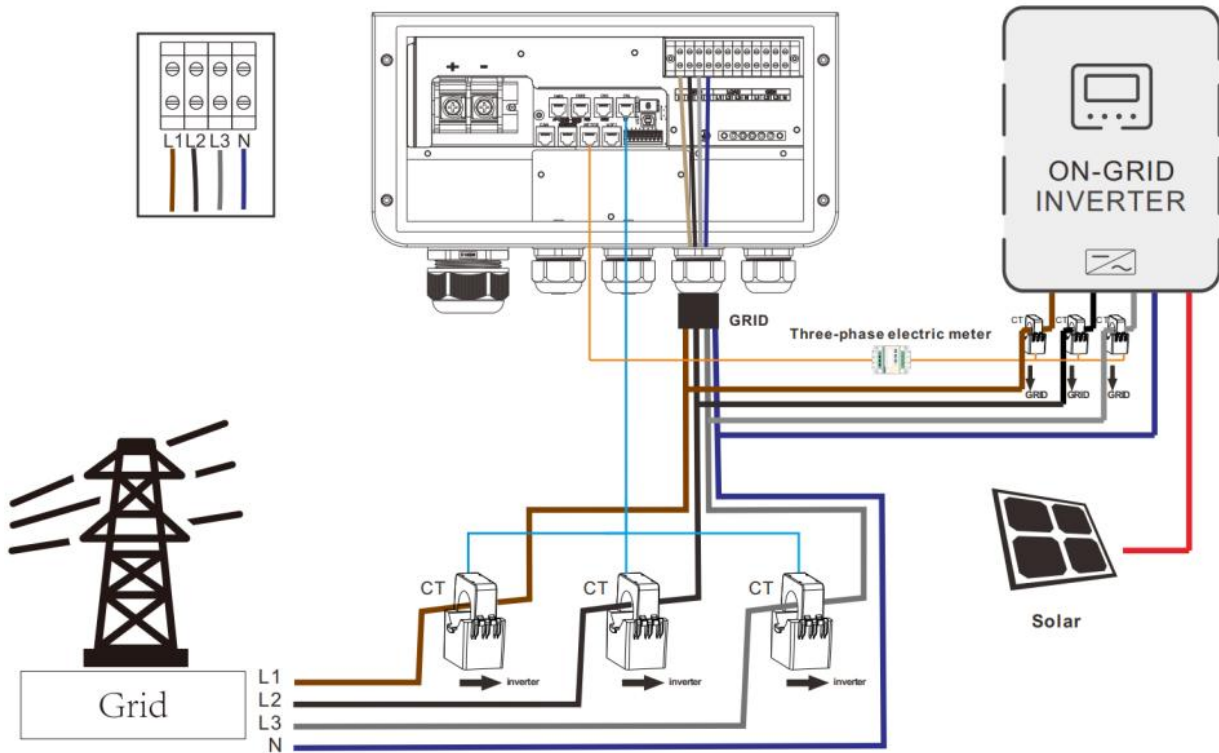

| RJ45       | Pin 1   | Pin 2   | Pin 3 | Pin 4 | Pin 5 | Pin 6 | Pin 7   | Pin 8   |
|------------|---------|---------|-------|-------|-------|-------|---------|---------|
| Definition | RS485-B | RS485-A | /     | /     | /     | /     | RS485-A | RS485-B |

1. Meter size: (mm)
2. CT size 1: (mm)

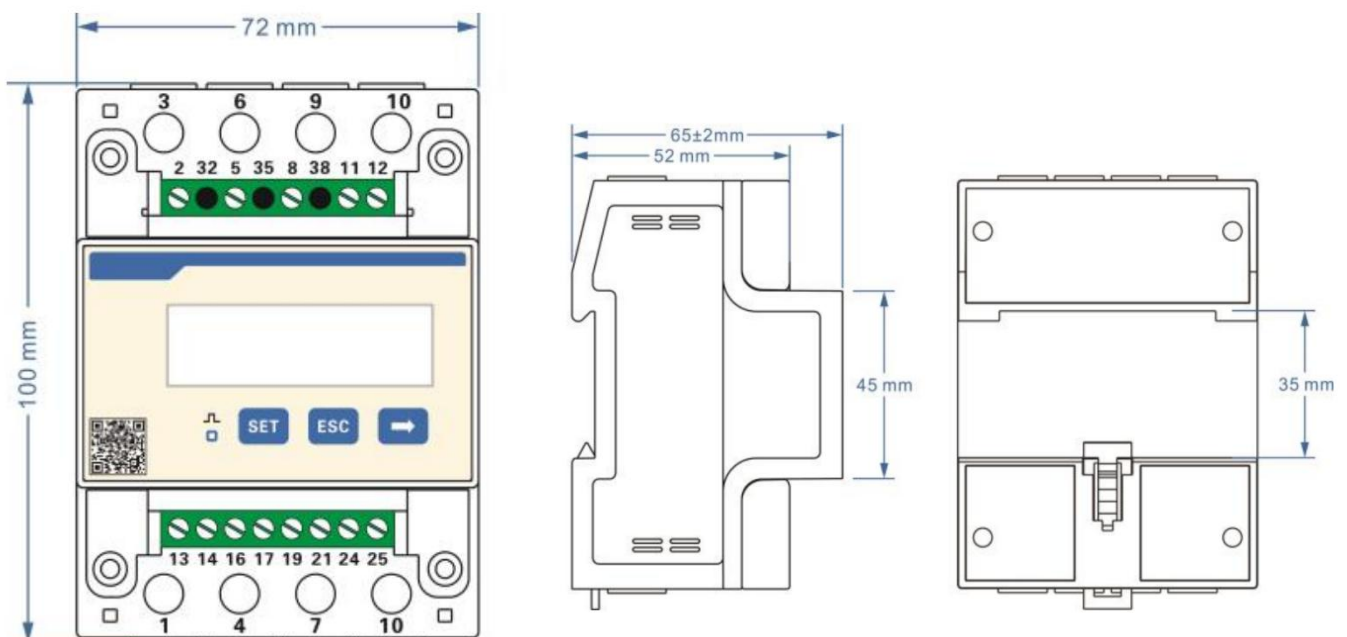

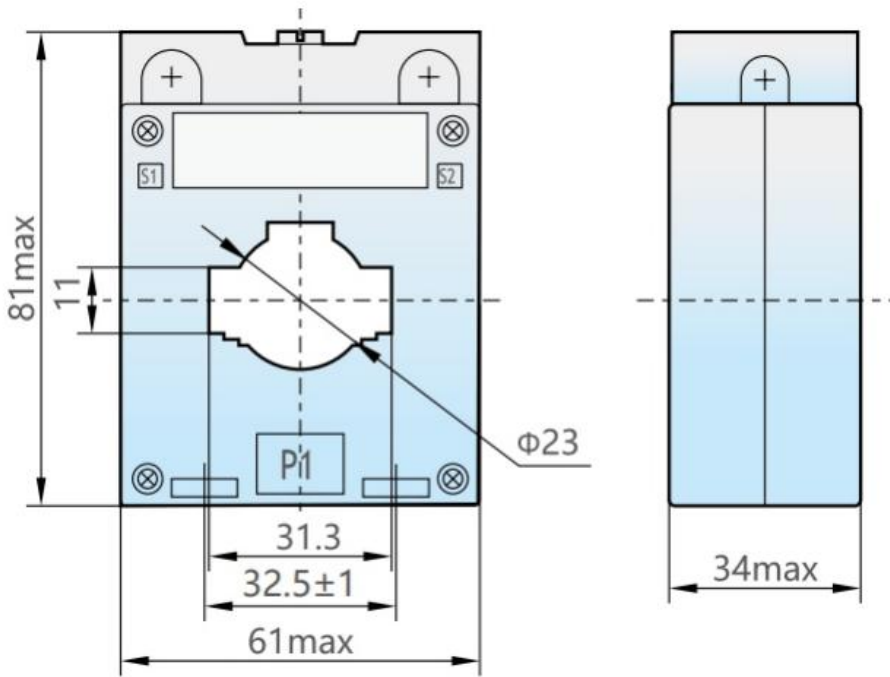

## 6.10 AC coupling function wiring

### 1.AC coupling - Grid side

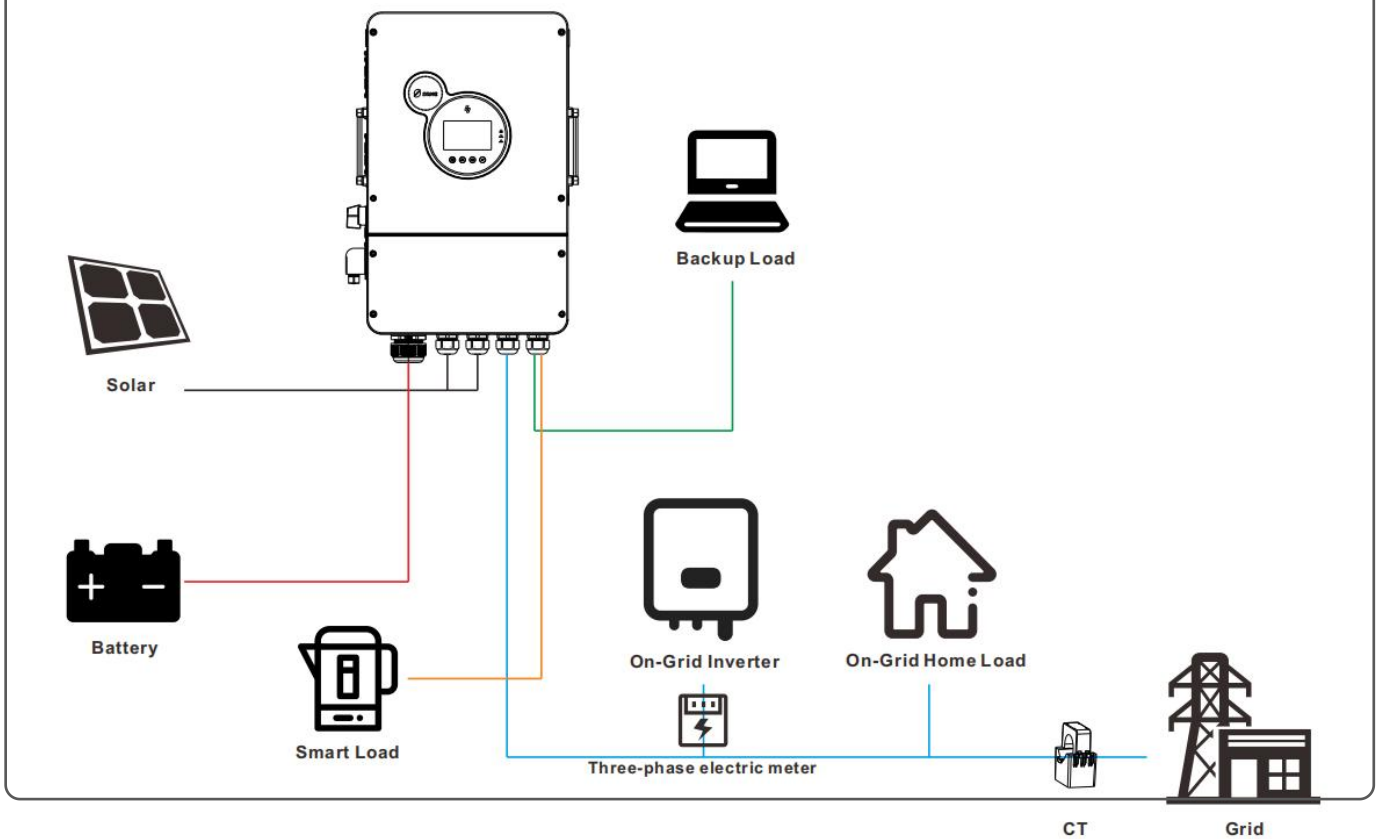

## 2.AC Coupling - Generator side

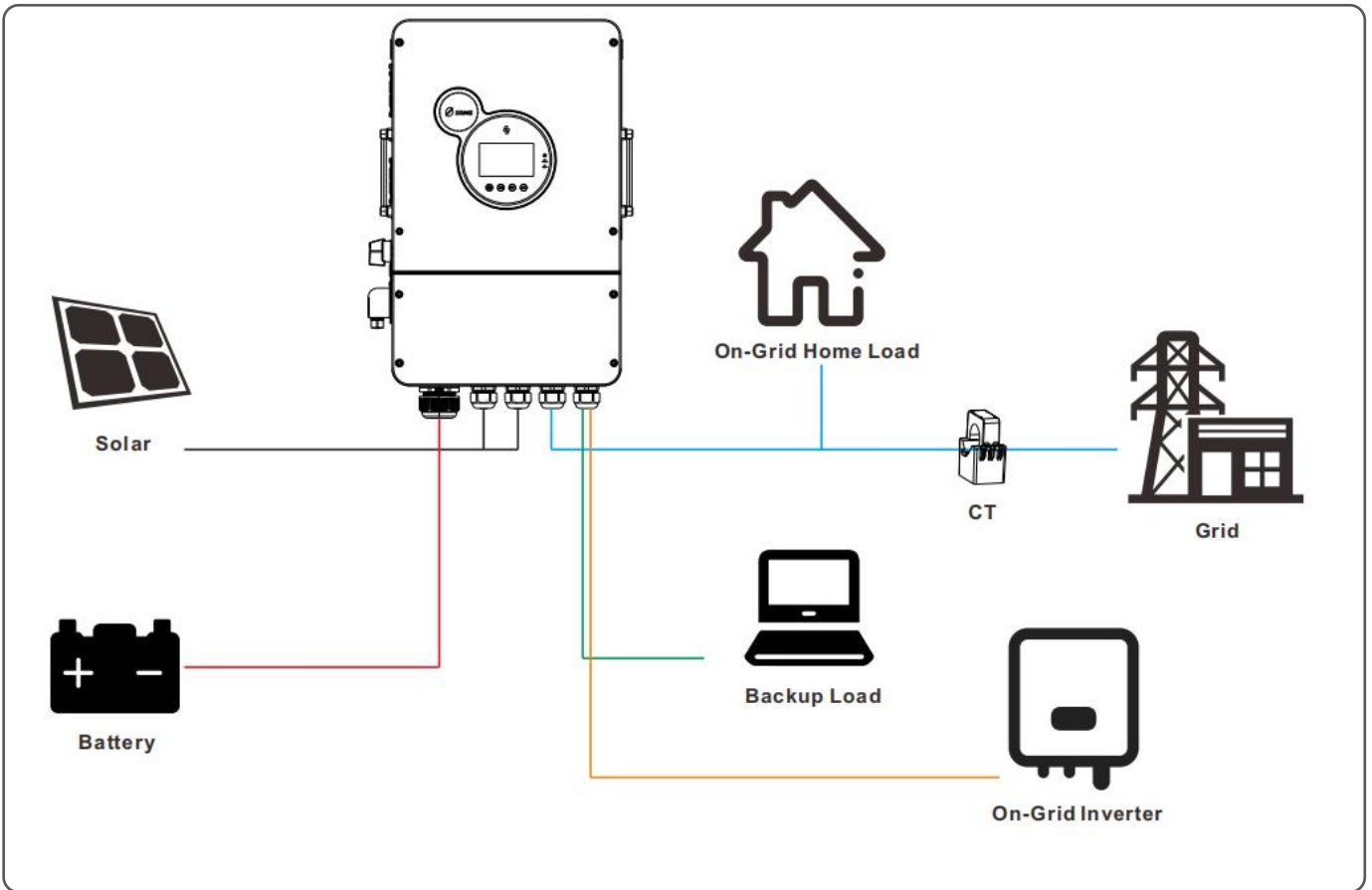

### 6.11 AC coupling function

The dry contact port has 3 functions.

1. RSD power supply
2. Temperature sampling (reserved)
3. Generator remote start/stop

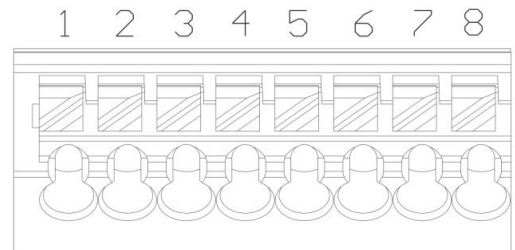

| Function                        | Definition  |
|---------------------------------|---|
| RSD power supply                | Pin 1 is GND and Pin 2 is RSD 12V+.   |
| Temperature Sampling (Reserved) | Pin 1 and Pin 5 can be used for battery temperature sampling compensation   |
| Generator remote start/stop     | 6 - 7: NC<br>6 - 8: NO<br>Remote generator shutdown: pins 6 - 7 normally closed, pins 6 - 8 normally open (Pin 6/7/8 output 125Vac/1A, 230Vac/1A, 30Vdc/1A) |

**NOTICE**

If you need to use the remote start/stop function of a dry contact generator, make sure that the generator has an ATS and supports the remote start/stop function.

# 7. Fault and Remedy

## 7.1 Fault code

| <b>Fault Code</b> | <b>Meaning</b>   | <b>Does it affect the output</b> | <b>Description</b>  | <b>Fault Level</b> |
|-------------------|------------------|----------------------------------|---|--------------------|
| 01                | BatVoltLow       | Not                              | Battery undervoltage alarm  | Grade 3            |
| 02                | BatOverCurrSw    | Yes                              | Battery discharge average current overcurrent software protection | Grade 2            |
| 03                | BatOpen          | Yes                              | Battery not connected alarm                                       | Grade 3            |
| 04                | BatLowEod        | Yes                              | Battery undervoltage stop discharging alarm                       | Grade 2            |
| 05                | BatOverCurrHw    | Yes                              | Battery overcurrent hardware protection                           | Grade 1            |
| 06                | BatOverVolt      | Yes                              | Charge overvoltage protection                                     | Grade 1            |
| 07                | BusOverVoltHw    | Yes                              | Busbar overvoltage hardware protection                            | Grade 1            |
| 08                | BusOverVoltSw    | Yes                              | Bus overvoltage software protection                               | Grade 1            |
| 09                | PvVoltHigh       | Not                              | PV overvoltage protection   | Grade 1            |
| 10                | PvAFCIErr        | Yes                              | PV Arcing Alarm   | Grade 1            |
| 11                | PvBoostOCHw      | Not                              | Boost overcurrent hardware protection                             | Grade 1            |
| 12                | SpiCommErr       | Yes                              | Master-slave SPI communication failure                            | Grade 2            |
| 13                | OverloadBypass   | Yes                              | Bypass overload protection  | Grade 2            |
| 14                | OverloadInverter | Yes                              | Inverter overload protection                                      | Grade 2            |
| 15                | AcOverCurrHw     | Yes                              | Inverter overcurrent hardware protection                          | Grade 1            |
| 16                | AuxDspReqOffPWM  | Yes                              | Slave Chip Shutdown Request Fault                                 | Grade 3            |
| 17                | InvShort         | Yes                              | Inverter short circuit protection                                 | Grade 1            |
| 18                | Bussoftfailed    | Yes                              | Bus soft-start fault  | Grade 1            |
| 19                | OverTemperMppt   | Not                              | PV Heatsink Over Temperature Protection                           | Grade 2            |
| 20                | OverTemperInv    | Yes                              | Inverter radiator over-temperature protection                     | Grade 2            |
| 21                | FanFail          | Yes                              | Fan Failure   | Grade 1            |
| 22                | EEPROM           | Yes                              | Memory failure  | Grade 1            |
| 23                | ModelNumErr      | Yes                              | Model setting error   | Grade 1            |
| 24                | Busdiff          | Yes                              | Positive and negative bus voltage imbalance                       | Grade 2            |

|    |                                   |     |  |         |
|----|-----------------------------------|-----|--|---------|
| 25 | BusShort                          | Yes | Bus short circuit  | Grade 1 |
| 26 | Rlyshort                          | Yes | Inverter AC output backfeed to bypass AC output                                      | Grade 1 |
| 27 | LinePhaselose                     | Yes | Grid input phase loss  | Grade 3 |
| 28 | LinePhaseErr                      | Yes | Grid input phase error   | Grade 3 |
| 29 | BusVoltLow                        | Yes | Low bus voltage protection   | Grade 2 |
| 30 | BatCapacityLow1                   | Not | Battery capacity rate below 10% alarm (effective after successful BMS communication) | Grade 3 |
| 31 | BatCapacityLow2                   | Not | Battery capacity rate below 5% alarm (Effective after successful BMS communication)  | Grade 3 |
| 32 | BatCapacityLowStop                | Yes | Battery low capacity shutdown (set BMS enable active)                                | Grade 2 |
| 33 | ControlCanFault                   | Yes | Control of CAN parallel operation faults   | Grade 2 |
| 34 | CanCommFault                      | Yes | Parallel can communication failure   | Grade 3 |
| 35 | ParaAddrErr                       | Yes | Incorrect parallel ID (communication address) setting                                | Grade 3 |
| 36 | Balance currentOC                 | Yes | Balanced bridge arm overcurrent fault  | Grade 1 |
| 37 | ParaShareCurrErr                  | Yes | parallel flow equalization fault   | Grade 2 |
| 38 | ParaBattVoltDiff                  | Yes | Parallel mode with large differences in battery voltage                              | Grade 2 |
| 39 | ParaAcSrcDiff                     | Yes | Parallel mode, inconsistent utility input source                                     | Grade 3 |
| 40 | ParaHwSynErr                      | Yes | Parallel mode, hardware synchronization signal failure                               | Grade 2 |
| 41 | InvDcVoltErr                      | Yes | Inverter voltage DC component  | Grade 2 |
| 42 | SysFwVersionDiff                  | Yes | Abnormal parallel program version inconsistency                                      | Grade 2 |
| 43 | ParaLineContErr                   | Yes | Faulty parallel wiring   | Grade 2 |
| 44 | Serial number error               | Yes | Serial number not set at factory   | Grade 2 |
| 45 | Error setting of split-phase mode | Yes | Parallel mode setting item set incorrectly   | Grade 2 |
| 46 | MeterComErr                       | Yes | Meter communication error  | Grade 2 |
| 48 | AFCIComErr                        | Yes | AFCI communication error   | Grade 1 |
| 49 | Grid over voltage                 | Yes | Set the local grid standard in the setup menu.                                       | Grade 4 |
| 50 | Grid under voltage                | Yes |  |         |

|    |                                 |     |   |         |
|----|---------------------------------|-----|---|---------|
| 51 | Grid over Frequency             | Yes |   |         |
| 52 | Grid under Frequency            | Yes |   |         |
| 53 | Grid loss                       | Yes |   |         |
| 54 | Grid DC current over            | Yes |   |         |
| 55 | Grid standard un init           | Yes |   |         |
| 56 | Low insulation resistance fault | Not | PV1+, PV2+, PV- impedance to ground abnormally low                        | Grade 4 |
| 57 | Leakage current overload fault  | Yes | System leakage current exceeds the standard                               | Grade 1 |
| 58 | BMSComErr                       | Not | BMS communication error   | Grade 4 |
| 60 | BMSUnderTem                     | Not | BMS low temperature alarm (effective after successful BMS communication)  | Grade 2 |
| 61 | BMSOverTem                      | Yes | BMS over-temperature alarm (effective after successful BMS communication) | Grade 2 |
| 62 | BMSOverCur                      | Yes | BMS overcurrent alarm (effective after successful BMS communication)      | Grade 2 |
| 63 | BMSUnderVolt                    | Not | BMS undervoltage alarm (effective after successful BMS communication)     | Grade 2 |

| <b>Fault sound and light level indication</b> |   |   |   |
|---|---|---|---|
| <b>Failure Level</b>                          | <b>Level Description</b>  | <b>Fault Lamp Status</b>                      | <b>Buzzer Status</b>  |
| Class 1                                       | Failure level alarm, the machine may be damaged and other serious faults.     | Fault Lamp Constant                           | Buzzer sounds for 0.5 seconds and stops for 0.5 seconds (more rapid audible alert). |
| Grade 2                                       | Output shuts down, stops charging, audible and visual alerts.                 | Fault light on for 1 second, off for 1 second | Buzzer sounds for 1 second, stops for 1 second (softer audible alert).              |
| Grade 3                                       | Setting error, external error, etc., the output may shut down, buzzer alerts. | Fault lamp does not light up                  | Buzzer sounds for 0.5 seconds and stops for 1.5 seconds (gentle audible alert).     |
| Grade 4                                       | Other alarms, does not affect the output and charging.                        | Fault lamp does not light up                  | Buzzer doesn't sound.   |

## 7.2 Partial Troubleshooting

| Fault Code | Meaning  | Causes   | Remedy  |
|------------|--|--|---|
| /          | No screen display  | No power input, or the switch on the bottom of the unit is not switched on.              | Check whether the battery air circuit-breaker or PV air circuit-breaker is turned on. Check if the switch is "ON". Press any button on the screen to exit the screen sleep mode.                        |
| 01         | Battery under-voltage  | The battery voltage is lower than the value set in parameter [battery under volt.alarm]. | Charge the battery and wait for the battery voltage to be higher than the value set by 'Battery setup'.   |
| 03         | Battery not connected  | The battery is not connected, or the BMS is in discharge protection state.               | Check that the battery is reliably connected. Check that the battery circuit-breaker is off. Ensure that the BMS is able to communicate properly.   |
| 04         | Battery over-discharge   | The battery voltage is lower than the value set in parameter [batt voltage low fault].   | Manual reset: Shut down and restart.<br>Auto reset: Charge the battery so that the battery voltage is higher than the voltage set by 'Battery setup'.   |
| 06         | Battery over-voltage when charging                                 | Battery overvoltage.   | Manually power down and restart. Check if the battery voltage exceeds the limit. If exceeded, the battery will need to be discharged until the voltage is below the battery overvoltage recovery point. |
| 13         | Bypass over-load (software detection)                              | Bypass output power or output current over-load for a period of time.                    | Reduce the load power and restart the device. Please refer to item 11 of the protection function for more details.  |
| 14         | Inverter over-load (software detection)                            | Inverter output power or output current over-load for a period of time.                  |   |
| 19         | Heat sink of PV input over-temperature (software detection)        | Heat sink of PV input temperature exceeds 90°C for 3s.                                   | Normal charging and discharging is resumed when the temperature of the heat sink cools below the over-temperature recovery temperature.   |
| 20         | Heat sink of inverter output over-temperature (software detection) | Heat sink of inverter output temperature exceeds 90°C for 3s.                            |   |
| 21         | Fan failure  | Hardware detects fan failure.  | Manually toggle the fan after powering off the machine to check for foreign matter blockage.  |

|    |                              |  |  |
|----|------------------------------|--|--|
| 26 | AC input relay short-circuit | Relay for AC input sticking.                   | Manually turn off and restart the machine, if the fault reappears after restarting, you need to contact the after-sales service to repair the machine. |
| 28 | Utility input phase fault    | AC input phase does not match AC output phase. | Make sure that the phase of the AC input is the same as the phase of the AC output.  |

 **NOTICE**

If you encounter product faults that cannot be solved by the methods in the above table, please contact our after-sales service department for technical support and do not disassemble the equipment by yourself.

## 8. Protection and maintenance

### 8.1 Protection function

| No. | Protection functions                      | Description  |
|-----|---|--|
| 1   | PV Input Current Limit Protection         | When the charging current or power of the PV array configured exceeds the PV input rated value, the inverter will limit the input power and charge at the rated.   |
| 2   | PV over-voltage protection                | If the PV voltage exceeds the maximum value allowed by the hardware, the machine reports a fault and stops PV boosting to output a sinusoidal AC waveform.   |
| 3   | Night-time anti-reverse charge protection | At night, the battery will be prevented from discharging to the PV module because the battery voltage is greater than the PV module voltage.   |
| 4   | Grid input overvoltage protection         | When the mains voltage of per phase exceeds 280Vac, the mains charging will be stopped and will switch to inverter output.   |
| 5   | Grid input undervoltage protection        | When the mains voltage of per phase falls below 170Vac, the mains charging will be stopped and will switch to inverter output.   |
| 6   | Battery overvoltage protection            | When the battery voltage reaches the over-voltage disconnection voltage point, it will automatically stop the PV and mains charging of the battery to prevent over-charging and damage to the battery.                   |
| 7   | Battery undervoltage protection           | When the battery voltage reaches the low-voltage disconnection voltage point, it will automatically stop discharging the battery to prevent the battery from being over-discharged and damaged.                          |
| 8   | Battery overcurrent protection            | When the battery current exceeds the range allowed by hardware, the machine will turn off output and stop discharging the battery.   |
| 9   | AC output short circuit protection        | When a short-circuit fault occurs at the load output for more than 200ms, it will immediately turn off the output AC voltage, and then manually re-power up and turn on the power in order to restore the normal output. |

|    |                                      |  |
|----|--------------------------------------|--|
| 10 | Radiator over-temperature protection | When the internal temperature of the inverter is too high, the inverter will stop charging and discharging; when the temperature returns to normal, the inverter will resume charging and discharging.   |
| 11 | Overload protection                  | <p>Three phase overload logic:<br/>           After triggering the overload protection, the inverter will resume output after 3 minutes, 5 consecutive overloads will shut down the output until the inverter is restarted.</p> <p>(102%&lt;load&lt;110%):alarm,output shut down after 5 minutes.<br/>           (110%&lt;load&lt;125%):alarm, output shut down after 20s.<br/>           (125%&lt;load&lt;200% ):alarm, output shut down after 10s.</p> <p>Single phase overload logic:<br/>           1.5*(102%&lt;load&lt;110%) :alarm, output shut down after 5 minutes.<br/>           1.5*(load&gt;110%): alarm, output shut down after 10s.</p> |
| 12 | AC reverse charge protection         | Prevents back-feeding of battery inverter AC power to bypass AC inputs.  |
| 13 | Bypass overcurrent protection        | Built-in AC input overcurrent protection circuit breaker.  |
| 14 | Bypass wiring error protection       | When the phase of the two bypass inputs is different from the phase of the inverter phase split, the machine will prohibit cutting into the bypass to prevent the load from dropping out or shorting out when cutting into the bypass.   |

## 8.2 Maintenance

To maintain optimum long-lasting working performance, it is recommended that the following items be checked twice a year.

1. Ensure that the airflow around the inverter is not blocked and remove any dirt or debris from the radiator.
2. Check that all exposed conductors are not damaged by sunlight, friction with other surrounding objects, dry rot, insect or rodent damage, etc. The conductors need to be repaired or replaced if necessary.
3. Verify that the indications and displays are consistent with the operation of the equipment, note any faults or incorrect displays and take corrective action if necessary.
4. Check all terminals for signs of corrosion, insulation damage, high temperatures or burning/discolouration and tighten terminal screws.
5. Check for dirt, nesting insects and corrosion, clean as required, clean insect screens regularly.
6. If the lightning arrester has failed, replace the failed arrester in time to prevent lightning damage to the inverter or other equipment of the user.



Make sure that the inverter is disconnected from all power sources and that the capacitors are fully discharged before carrying out any checks or operations to avoid the risk of electric shock.

**The Company shall not be liable for damage caused by :**

1. Damage caused by improper use or use in a wrong location.
2. PV modules with an open-circuit voltage exceeding the maximum permissible voltage.
3. Damage caused by the operating temperature exceeding the restricted operating temperature range.
4. Dismantling and repair of the inverter by unauthorised persons.
5. Damage caused by force majeure: damage during transport or handling of the inverter.

## 9.Datasheet

| Models                            | HESP Series   |         |         |         |         |          |
|-----------------------------------|---|---------|---------|---------|---------|----------|
|                                   | 4830SH3   | 4840SH3 | 4850SH3 | 4860SH3 | 4870SH3 | 4880SHD3 |
| <b>Inverter Output</b>            |   |         |         |         |         |          |
| Rated Output Power                | 3000W   | 4000W   | 5000W   | 6000W   | 7000W   | 8000W    |
| Max. Peak Power                   | 6000VA  | 8000VA  | 10000VA | 12000VA | 14000VA | 16000VA  |
| Rated Output Voltage              | 230/400Vac (L1+L2+L3+N+PE )   |         |         |         |         |          |
| Output Voltage Error              | ±5%   |         |         |         |         |          |
| Load Motor Capacity               | 3HP   | 3HP     | 4.5HP   | 6HP     | 6HP     | 6HP      |
| Rated Frequency                   | 50/60Hz ± 0.3Hz   |         |         |         |         |          |
| Output Waveform                   | Pure sine wave  |         |         |         |         |          |
| Switch Time                       | 10ms (typical)  |         |         |         |         |          |
| Overload Protection               | <p>Three-phase overload logic.</p> <p>After triggering the overload protection, the inverter restores the output after 3 minutes, 5 consecutive overloads turn off the output until the inverter restarts.</p> <p>(102%&lt;load&lt;110%):Alarm, output off after 5 minutes.</p> <p>(110%&lt;load&lt;125%):Alarm, output off after 20s.</p> <p>(125%&lt;load&lt;200%):alarm, output off after 10s.</p> <p>Single-phase overload logic.</p> <p>1.5*(102%&lt;load&lt;110%):Alarm, output off after 5 minutes.</p> <p>1.5*(load&gt;110%):alarm, output off after 10s.</p> |         |         |         |         |          |
| <b>AC Output (grid-connected)</b> |   |         |         |         |         |          |
| Rated Output Power                | 3000W   | 4000W   | 5000W   | 6000W   | 7000W   | 8000W    |
| Max. Apparent Power               | 3000VA  | 4000VA  | 5000VA  | 6000VA  | 7000VA  | 8000VA   |

|                                 |   |        |                           |                 |                 |                 |
|---------------------------------|---|--------|---------------------------|-----------------|-----------------|-----------------|
| Power Factor                    | 0.8 ahead, 0.8 behind                               |        |                           |                 |                 |                 |
| Rated Output Voltage            | 230/400Vac (L1+L2+L3+N+PE )                         |        |                           |                 |                 |                 |
| Rated Grid Frequency            | 50/60Hz   |        |                           |                 |                 |                 |
| Rated AC Output Current         | 4.4Aac  | 5.8Aac | 7.2Aac                    | 8.7Aac          | 10.1Aac         | 11.6Aac         |
| THD                             | <3%   |        |                           |                 |                 |                 |
| <b>Battery</b>                  |   |        |                           |                 |                 |                 |
| Battery Type                    | Li-ion / Lead-Acid / User Defined                   |        |                           |                 |                 |                 |
| Rated Battery Voltage           | 48Vdc ( Minimum Startup Voltage 44V )               |        |                           |                 |                 |                 |
| Voltage Range                   | 40 ~ 60Vdc  |        |                           |                 |                 |                 |
| Max. Generator Charging Current | 50Aac   | 60Aac  | 80Aac                     | 100Aac          | 120Aac          | 140Aac          |
| Max. Grid Charging Current      | 50Aac   | 60Aac  | 80Aac                     | 100Aac          | 120Aac          | 140Aac          |
| Max. Hybrid Charging Current    | 80Aac   | 100Aac | 120Aac                    | 150Aac          | 180Aac          | 200Aac          |
| <b>PV Input</b>                 |   |        |                           |                 |                 |                 |
| No. of MPPT Trackers            | 1   |        | 2                         |                 |                 |                 |
| Max. Input Power                | 6000W   | 8000W  | 5000W<br>+5000W           | 6000W<br>+6000W | 7000W<br>+7000W | 8000W<br>+8000W |
| Max. Input Current              | 26Aac   |        | 26Aac+26Aac               |                 |                 |                 |
| Max. Short-circuit Current      | 35Aac   |        | 35Aac+35Aac               |                 |                 |                 |
| Max. Open Circuit Voltage       | 800Vdc  |        | 800Vdc/800Vdc             |                 |                 |                 |
| MPPT Voltage Range              | 200 ~ 650Vdc  |        | 200 ~ 650Vdc/200 ~ 650Vdc |                 |                 |                 |
| <b>Grid / Generator Input</b>   |   |        |                           |                 |                 |                 |
| Input Voltage Range             | Phase voltage 170 to 280V, Line voltage 305 to 485V |        |                           |                 |                 |                 |
| Input Frequency Range           | 50Hz/60Hz   |        |                           |                 |                 |                 |
| Bypass Overload Current         | 45A   |        |                           |                 |                 |                 |
| <b>Efficiency</b>               |   |        |                           |                 |                 |                 |
| MPPT Tracking Efficiency        | 99.9%   |        |                           |                 |                 |                 |
| Max. Efficiency                 | ≥92%  |        |                           |                 |                 |                 |
| European Efficiency             | 97.0%   |        |                           |                 |                 |                 |

| <b>Protection</b>                      |  |
|--|--|
| PV Lightning Protection                | √  |
| Anti-islanding Protection              | √  |
| PV Input Reverse Connection Protection | √  |
| Insulation Impedance Detection         | √  |
| Leakage Current Detection              | √  |
| Output Overcurrent Protection          | √  |
| Output Short Circuit Protection        | √  |
| Surge Protection                       | DC type II/AC type II                                  |
| Overvoltage Protection Level           | DC type II/AC type III                                 |
| <b>Accreditation</b>                   |  |
| Grid Connection Certification          | EN50549,VDE4105  |
| Safety Regulations                     | IEC62109-1, IEC62109-2                                 |
| EMC                                    | IEC/EN 61000-6-1/2/3/4, IEC/EN 62109-1, IEC/EN 62109-2 |
| RoHS                                   | Yes  |
| <b>General Data</b>                    |  |
| Parallel Capacity                      | 6  |
| Operating Temperature                  | -25 ~ 60°C, >45°C Derated                              |
| Humidity Range                         | 0 ~ 100%   |
| Noise                                  | <55dB  |
| Protection Class                       | IP65   |
| Cooling Method                         | Heat sink + intelligent fan cooling                    |
| Self-consumption Power                 | <100W  |
| Dimension                              | 640*400*250mm (excluding hangers and connectors)       |
| Weight                                 | 37.5kg   |
| Communication Port                     | RS485/CAN  |
| External Module                        | WIFI/4G Stick(Optional)                                |

## **SRNE Solar Co,.Ltd**

---

**Mail**      [service@szshuori.com](mailto:service@szshuori.com)

---

**Web**        [www.srnesolar.com](http://www.srnesolar.com)

---

**Address**    4-5F,Building13A,Taihua Wutong  
Industrial Park ,Gushu Development  
Zone , Hangcheng Street,Baoan,  
Shenzhen, China PR

---